

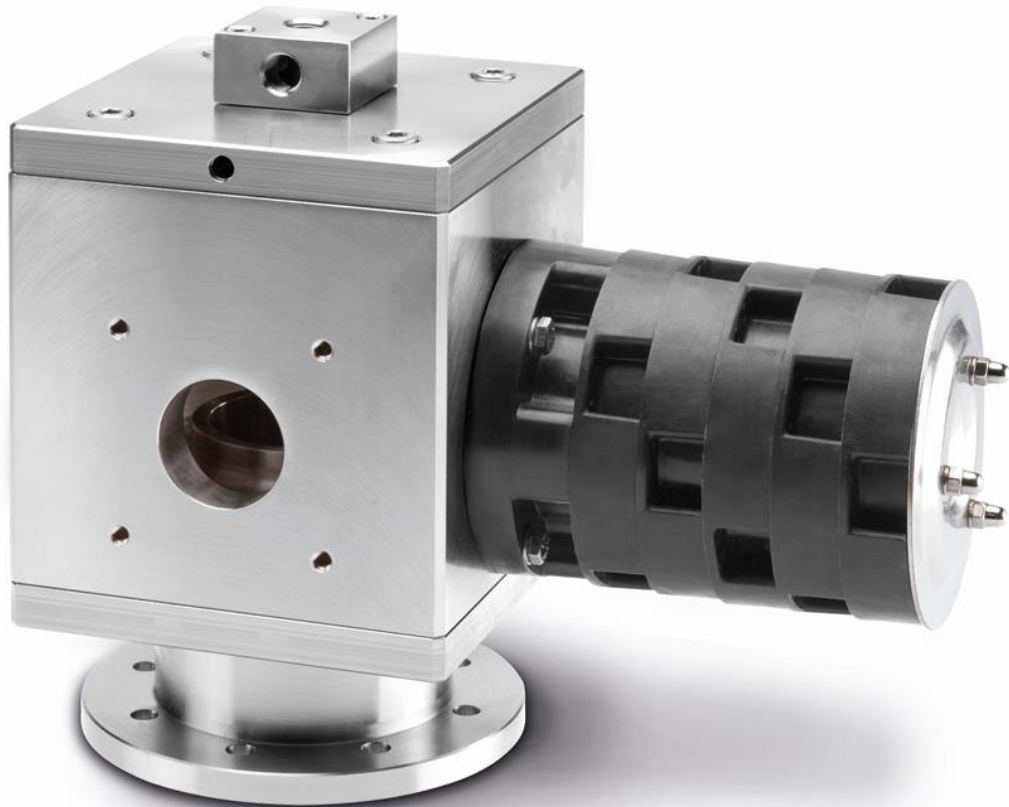

CS / SE – QUICK EXHAUST INSTRUCTION MANUAL 2091



*Engineering
GREAT Solutions*

<i>Rev.</i>	<i>Date</i>	<i>Description</i>	<i>By</i>	<i>Approved</i>
00	04/04/2016	First issue	N.Zenoni	F.Tondolo
04	15/03/2019	Certificate Renewal	N.Mores	G.Alfieri

STI S.r.l. has taken every care in collecting and verifying the documentation contained in this Instruction Manual. The information herein contained are reserved property of STI S.r.l.

INDEX

1	GENERAL INFORMATION	1
1.1	GENERAL WARNINGS.....	1
1.2	GENERALITIES.....	1
1.3	MANUFACTURER.....	1
1.4	TERMS AND CONDITIONS	1
1.5	MANUFACTURER'S LIABILITY.....	1
1.6	APPLICABLE STANDARDS AND DIRECTIVES	2
1.7	SYMBOLOLOGY USED.....	2
1.7.1	<i>Signs of warning</i>	2
1.7.2	<i>Signs of obligation</i>	2
2	DEVICE DESCRIPTION	3
2.1	GENERAL DESCRIPTION.....	3
3	TECHNICAL DATA.....	6
4	LABEL.....	7
5	INSTALLATION	8
5.1	TRANSPORT	8
5.2	RECEPTION.....	8
5.3	STORAGE.....	8
5.4	REQUIREMENTS OF STABILITY	8
5.5	DOCUMENTS AND DIMENSIONAL DRAWINGS.....	9
5.6	INSTALLATION.....	9
5.6.1	<i>Checks to be performed before installation</i>	9
6	OPERATION AND USE.....	11
6.1	OPERATING CONDITIONS.....	11
6.2	INTENDED USE.....	11
7	TRANSPORT	12
8	RECEPTION.....	12
9	STORAGE.....	12
10	INSTRUCTION FOR THE OPERATORS	13
10.1	FIELD ACTIVITIES	13
10.2	RESIDUAL RISKS	13
11	MAINTENANCE	14
11.1	PERIODIC INSPECTIONS AND MAINTENANCE.....	14
11.2	EXTRAORDINARY MAINTENANCE	14
12	PARTS LIST GENERAL ASSEMBLY	15
12.1	CS / SE.....	15
13	TROUBLESHOOTING	17
14	SPARE PARTS	17
15	DISASSEMBLING.....	17
16	DECOMMISSIONING.....	18

1 GENERAL INFORMATION

1.1 General Warnings

Important 	This Instruction Manual is an integral part of the machine, it should be carefully read before carrying out any operation and it should be kept for future references. The operators shall adopt the safety precautions required by the country where the product is installed. This Instruction Manual is realized in accordance with the Directive 2006/42/CE.
---	---

1.2 Generalities

STI S.r.l. actuators are conceived, manufactured and controlled according to the Quality management System in compliance with EN ISO 9001 International Standard.

1.3 Manufacturer

With respect to Machinery Directive 2006/42/EC, the Manufacturer of the described CO 3 way pneumatic valve is STI S.r.l. as specified on the label.

STI S.r.l. Via Dei Caravaggi 15
24040 Levate (BG) Italy
Tel. +39 035 2928.2
Fax +39 035 2928.247
imisti.sales@imi-critical.com

1.4 Terms and conditions

STI S.r.l. guarantees each single product to be free from defects and to conform to current goods specifications. The warranty period is two years from the date of shipment to the first user. The warranty does not cover special products or components not covered by warranty in their turn by subcontractors. No warranty is given for products which have been subject to improper storage, improper installation, improper maintenance or which have been modified or repaired by unauthorised personnel.

1.5 Manufacturer's liability

The CS / SE quick exhaust is designed in accordance with the applicable International Rules and Specifications, but the following regulations must be observed in any case:

- the general and safety regulations;
- the plant specific regulations and requirements;
- the proper use of personal devices, protective devices (glasses, clothing, gloves, etc), tools and transport equipment.

STI S.r.l. declines all liability in the event of:

- use CS / SE quick exhaust in other applications than the designated ones;
- use of the CS / SE quick exhaust in contravention of local safety at work legislation;
- lack of care during transport, installation, operations, maintenances of the CS / SE quick exhaust or incorrect application of the instructions provided on the CS / SE quick exhaust label and in this manual;
- modifications or repairs without STI S.r.l. authorisation;
- work done on the unit by unqualified or unsuitable operators.

Considering that STI S.r.l. has no direct control over particular applications, operation or maintenance conditions, it is the operator's responsibility to comply with all applicable safety rules; it is the sole responsibility of the operator to ensure that the local health and safety regulations are adhered to. Depending on the specific working conditions, additional precautions may be requested.

Please inform STI S.r.l. urgently if you face unsafe situations not described in this Instruction Manual.

1.6 Applicable Standards and Directives

EN ISO 12100:2010	Safety of machinery - General principles for design - Risk assessment and risk reduction
IEC 61508:2010	Functional safety of electrical / electronic / programmable electronic safety-related systems
2006/42/EC	Machinery Directive
2014/68/UE	Pressure Equipments Directive (PED)
2014/34/UE	Equipments used in potentially explosive atmospheres (ATEX)

1.7 Symbology used

1.7.1 Signs of warning

Be careful where these symbols are shown, they indicate a potentially hazardous situation and they warn that if the steps are not properly performed, MAY RESULT CAUSING serious injury, death or long-term risks to the health of exposed persons.



GENERAL DANGER



DANGER POWER SUPPLY



CRUSHING HAZARD

1.7.2 Signs of obligation



General obligation (with the possible supplementary signboard)



Must wear protective clothing.



Must wear protective footwear.



Must wear protective helmet.



Must wear protective glasses



Must wear earplugs

2 DEVICE DESCRIPTION

2.1 General Description

The STI S.r.l. quick exhaust exists in two different sizes: CS is the lower one and SE is the greater one. Each quick exhaust is made by a body containing a shutter able to connect two different pneumatic ways depending on the delta pressure between the pilot (port P) and the users (port U). If the CS / SE quick exhaust is “de-energized”, the port U (users) is connected to the port E (exhaust), vice versa if the CS / SE quick exhaust is “energized” the port U and E are not connected.

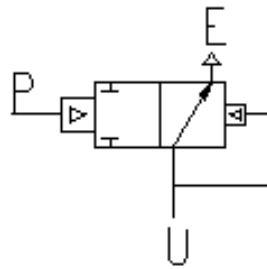

Figure 1 – CS / SE quick exhaust symbol (de-energize)

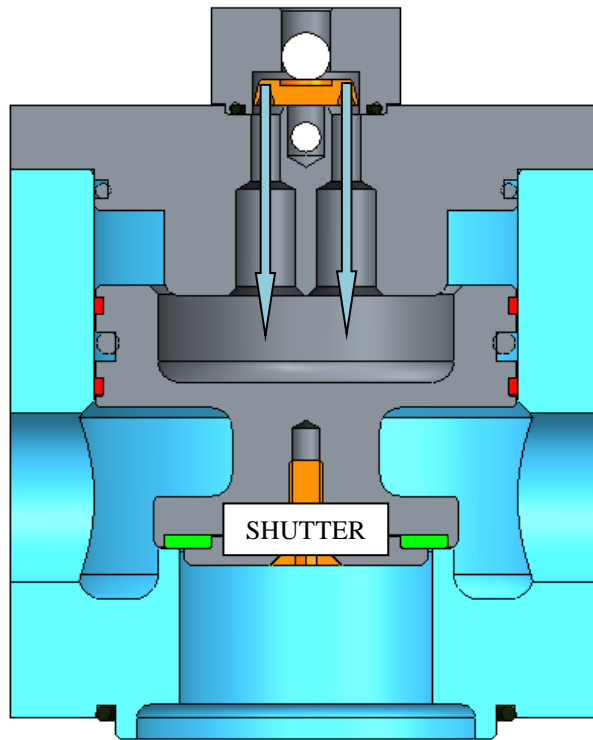

Figure 2 – CS quick exhaust: energized

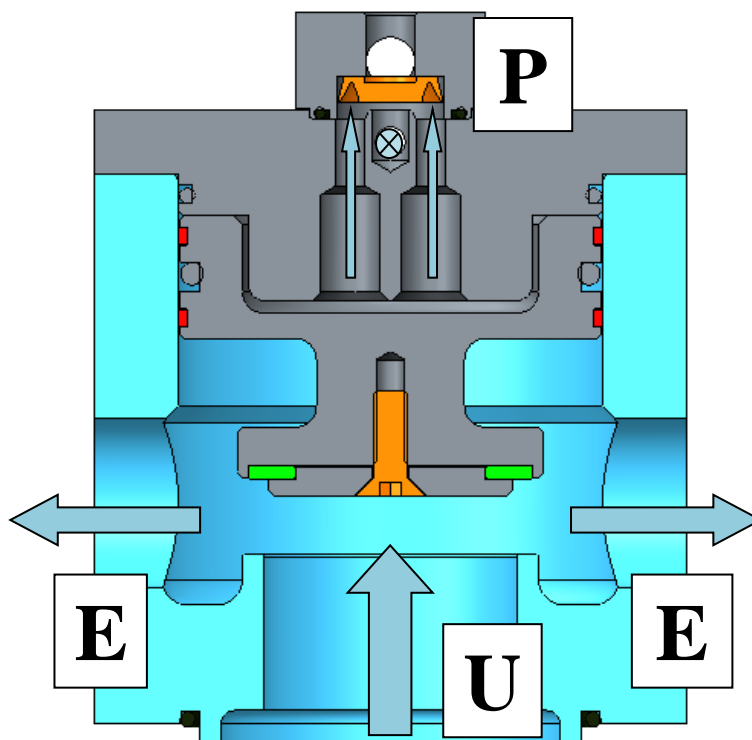

Figure 3 – CS quick exhaust: de-energized

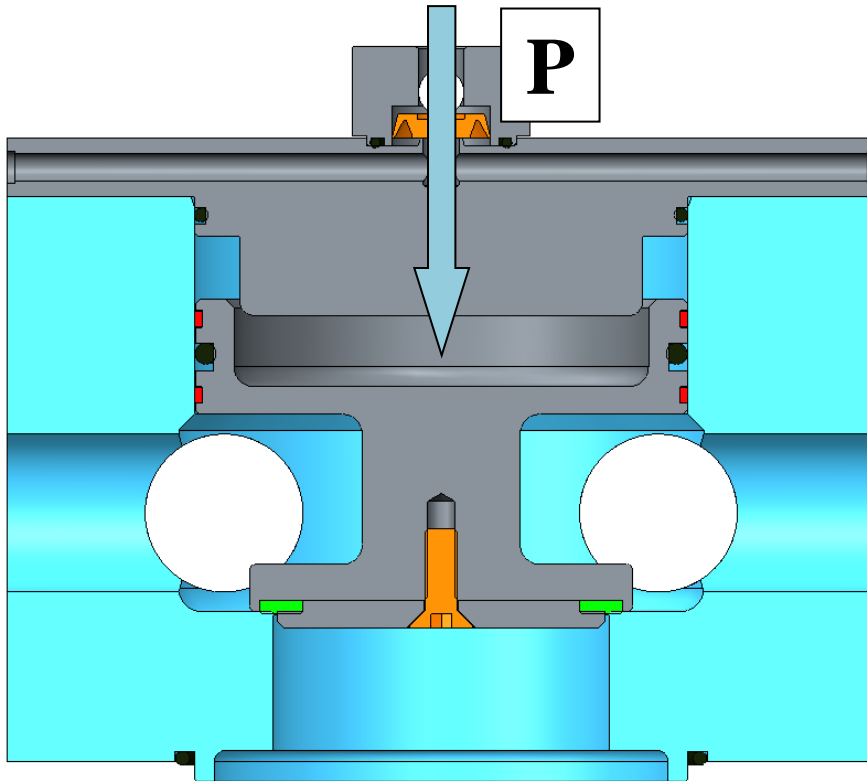

Figure 4 – SE quick exhaust: energized

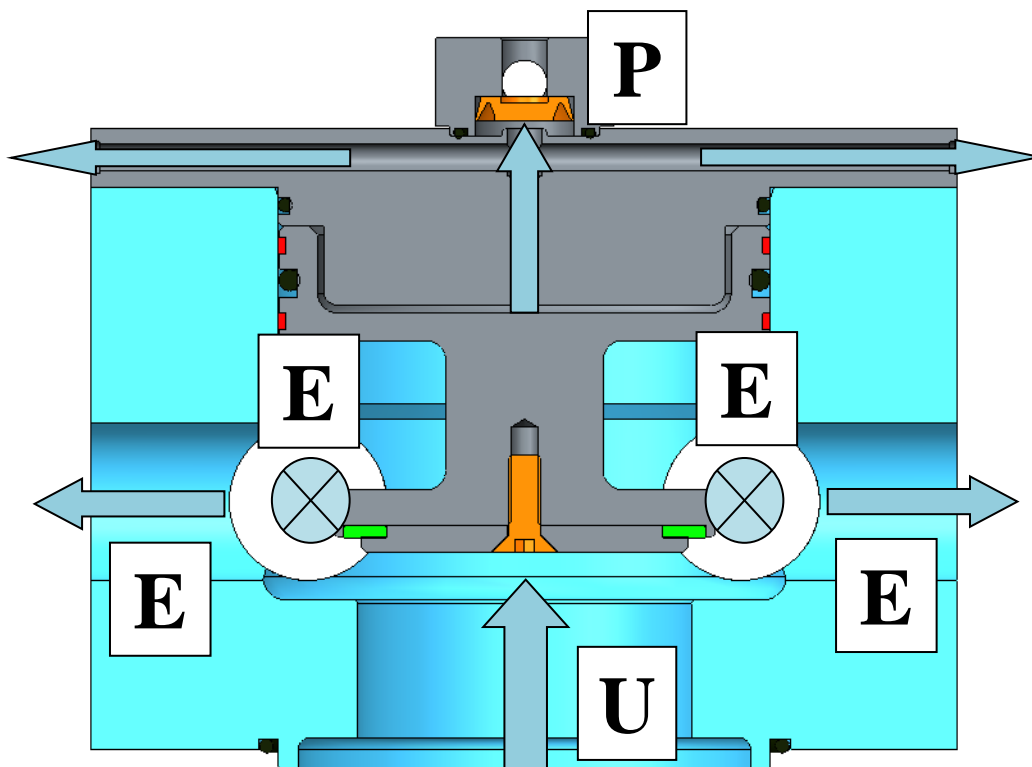

Figure 5 – SE quick exhaust: de-energized

3 TECHNICAL DATA

	CS		SE
Material	Aluminum	Aluminum	Aluminum
	Stainless steel	Stainless steel	Stainless steel
Design pressure	p = 10 bar	p = 10 bar	p = 10 bar
Standard operating temperature (*)	T _{min} = -20 °C	T _{min} = -20 °C	T _{min} = -20 °C
	T _{max} = +70 °C	T _{max} = +70 °C	T _{max} = +70 °C
Storage temperature	T _{min} = -40 °C	T _{min} = -40 °C	T _{min} = -40 °C
	T _{max} = +80°C	T _{max} = +80°C	T _{max} = +80°C
Port P	1/4"	1/4"	1/4"
Port U	Ø60	Ø60	Ø85
Port E	n°2 Ø40 (n°2 SL 5elements)	n°3 Ø40 (n°3 SL 5elements)	n°6 Ø40 (n°6 SL 5elements)
Expected lifetime	20 years	20 years	20 years

(*) For some special application the operating temperature range could be another one included in the extended temperature range from -40°C to 100°C.

4 LABEL

The plate fastened on the CS / SE contains the main operating conditions. The supply can be instrument air or natural gas. It is forbidden to modify the information and the marks without previous written authorization by STI S.r.l.

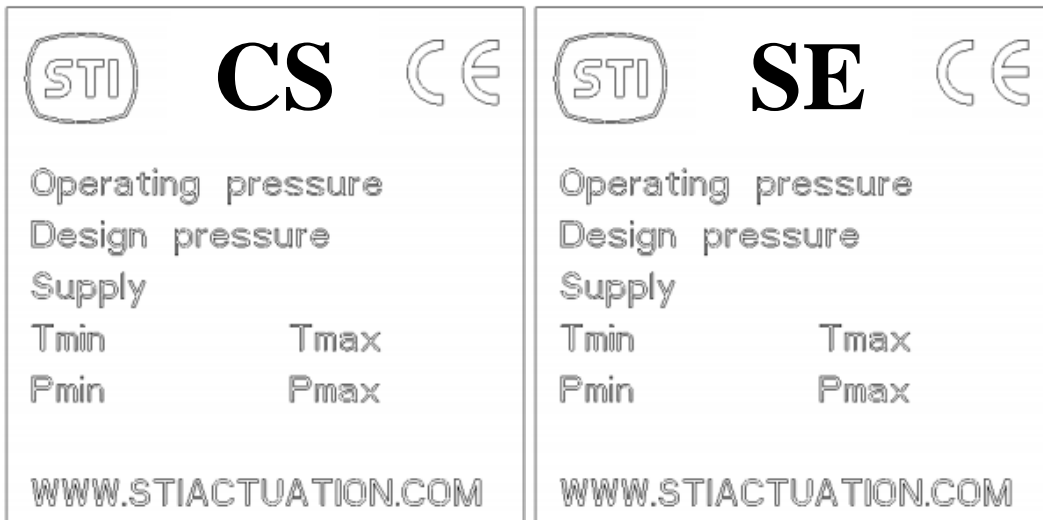





Figure 6 – CS/SE standard label

<p>Warning</p> 	<p>It is severely forbidden to use CS / SE quick exhaust under conditions other than those provided on the label.</p>
<p>Important</p> 	<p>It is forbidden to modify the information and the marks without previous written authorization by STI S.r.l. Do not remove the label and/or replace with other label.</p>

5 INSTALLATION

<p>Warning</p> 	<p>The following instructions must be respected:</p> <ul style="list-style-type: none"> - operations must be carried out only by skilled operators; - always wear protective clothing, gloves, and eyewear to prevent personal injury. Check with your process or safety engineer for any additional measures that must be taken to protect against process media.
---	---

<p>Important</p> 	<p>Not performing the following procedures will invalidate the product warranty.</p>
---	---

5.1 Transport

<p>Important</p> 	<p>The lifting and handling should be made by qualified staff and in compliance with the laws and provisions in force.</p>
--	---

5.2 Reception

It is recommended to check CS / SE quick exhaust conditions before the installation, then:

- prepare the necessary tools for the assembly and setting of the unit;
- check that the CS / SE quick exhaust size meet the specified dimensions;
- clean the CS / SE quick exhaust surfaces and remove anything that might prevent a perfect adherence with the actuator or other accessories.

5.3 Storage

CS / SE quick exhaust leaves the factory in perfect conditions. Performances of each unit are guaranteed by tests and data reported on the specific. To maintain these conditions until the CS / SE is installed on site, proper attention must be observed for preservation during the storage period.

If the CS / SE needs storage, before installation follow these steps:

- place it on a wood surface pallet or on metallic support, thus it is not in direct contact with the ground, and packed with appropriate covering;
- make sure that plastic plugs are present on the pneumatic connections;
- keep the CS / SE protected from direct weather conditions;
- if stored outdoor, replace plastic plugs on pneumatic connections with metal plugs that guarantee perfect tightness.
- storage temperature must be between -40°C and +80°C.

5.4 Requirements of Stability

Concerning the requirement of stability during installation and disassembling, it is possible to refer to the next chapters 5.6 and 5.7.

5.5 Documents and dimensional drawings

Pneumatic diagrams, wiring diagrams and dimensional drawings are furnished with document accompanying the actuator.

5.6 Installation

Warning 	<p>Before proceeding with any Installation, the following instructions must be respected:</p> <ul style="list-style-type: none"> - Always wear protective clothing, gloves, and eyewear to prevent personal injury; - Check with your process or safety engineer for any additional measures that must be taken to protect against process media.
---	--

5.6.1 Checks to be performed before installation

- Check that the coupling dimensions meet the specified coupling dimensions.
- Prepare the necessary tools for the assembly and setting of the unit.
- Check that the outer surface of the Cs / SE is free from dust and dirt.
- Clean the CS / SE surfaces and remove anything that might prevent a correct installation.

Warning 	<p>Check if the CS / SE quick exhaust has a properly earthing connection.</p>
--	--

The earthing connection is guaranteed through the fixing screws of the CS / SE quick exhaust. If the earthing connection of the system where CS / SE quick exhaust is mounted is not guaranteed, it is required to ensure a directly earthing connection from the screws.

Warning 	<p>Check that the values of pneumatic supply available are compatible with those reported on the label of the CS / SE quick exhaust: a pressure regulator is absolutely necessary when supply pressure is higher than max operating pressure.</p> <p>User must consider and take all precautions to avoid that pressurized parts are not used out of specified range and to avoid exposure to fire.</p>
---	---

Important 	<p>For easier maintenance, it is recommended to install a filter with five-micron cartridge and shut-off valve on the supply connection.</p>
---	---

It is required to follow these steps during the pneumatic connection:

- no lubricators on supply fluid line is required;
- use pipes and connections appropriate as for type, rating, material and dimensions;
- properly deburr the ends of rigid pipes;
- properly clean the interior of pipes sending through them plenty of the supply fluid;
- use pipe sealant sparingly and only on male threads. A non-hardening sealant is strongly recommended;
- fasten the connection pipes so that no irregular strains or loosening of threaded connections occur;
- make the pneumatic connections according to the pneumatic diagram;

- check the absence of leakages from pneumatic connections. If necessary, tighten the nuts of the pipe-fittings;
- after connecting the CS / SE quick exhaust, gradually increase the supply pressure up to the maximum operating pressure.

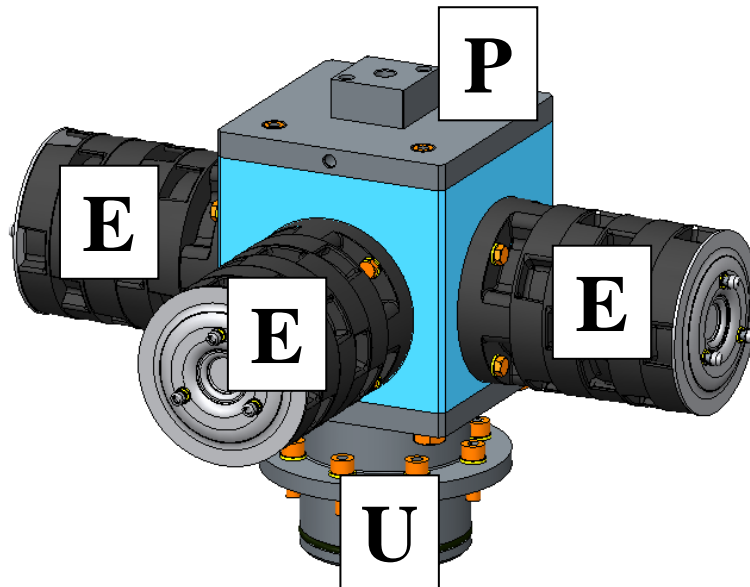

Figure 7 – CS quick exhaust (with SL silencers)

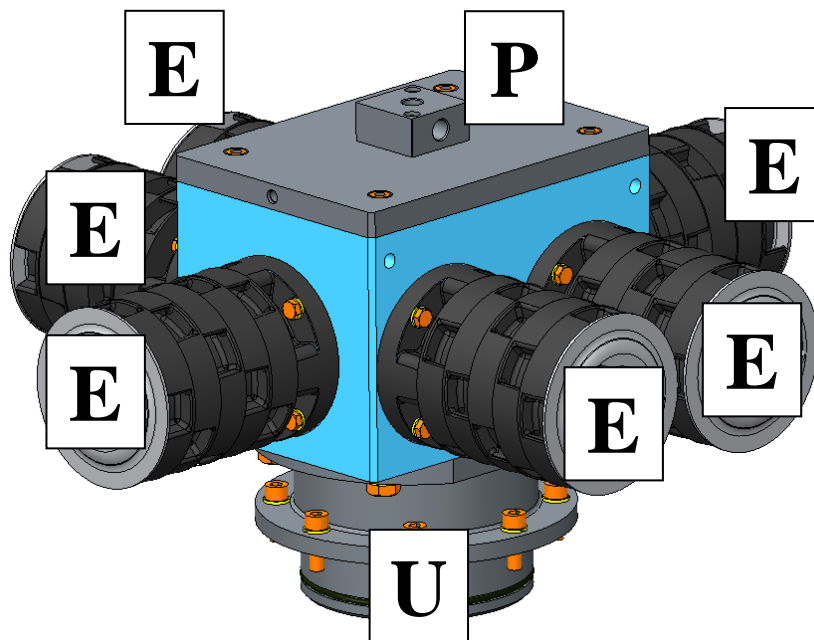

Figure 8 – SE quick exhaust (with SL silencers)

6 OPERATION AND USE

Warning



It is severely forbidden to use the CS / SE quick exhaust for purpose or application other than those for which it was designed and here specified.

6.1 Operating conditions

The label fastened on the CS / SE quick exhaust contains the main operating conditions for the specified application (see Section 4). Other operating conditions are reported in the documents accompanying the actuator. For general operating conditions see Section 3.

6.2 Intended use

The CS / SE quick exhaust are designed for high flow applications and need a signal pilot in order to change its status (2 possible positions) As referred in chapter 2.1.

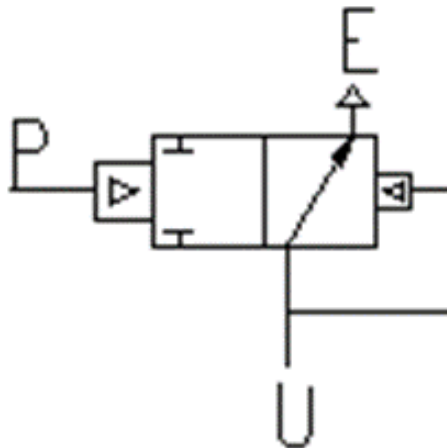



Figure 7 – CS / SE quick exhaust pneumatic circuit (de-energize)

7 TRANSPORT

<p>Warning</p> 	<p>The following instructions must be respected:</p> <ul style="list-style-type: none"> - operations must be carried out only by skilled operators; - always wear protective clothing, gloves, and eyewear to prevent personal injury. Check with your process or safety engineer for any additional measures that must be taken to protect against process media.
---	---

<p>Important</p> 	<p>The lifting and handling should be made in compliance with the laws and provisions in force.</p>
---	--

8 RECEPTION

CO 3-way pneumatic valve leave the factory in perfect condition. At the reception of the CO 3-way pneumatic valve:



- check that the model corresponds with that of order confirmation;
- check that the CS / SE quick exhaust was not damaged during transportation. If necessary, renovate the painting according to the specification reported on the order confirmation.

9 STORAGE

In order to maintain the guaranteed actuator performances until the CS / SE quick exhaust is installed on site, proper attention must be observed for preservation during the storage period. If the CS / SE quick exhaust needs storage before installation:

- place it in a dry, clean place and take all necessary measures to avoid contact with dust, dirt and humidity during storage;
- protect the CS / SE quick exhaust from weather conditions;
- make sure that connection protections and/or the mechanical locks will not be removed during the storage (for long-term storage replace the plastic plugs with metal plugs);
- storage temperature must be between -40°C and +80°C.

10 INSTRUCTION FOR THE OPERATORS

<p>Warning</p> 	<p>Preloaded spring inside.</p>
<p>Warning</p> 	<p>The following instructions must be respected:</p> <ul style="list-style-type: none"> - operations must be carried out only by skilled operators; - always wear protective clothing, gloves, and eyewear to prevent personal injury. Check with your process or safety engineer for any additional measures that must be taken to protect against process media.
<p>Important</p> 	<p>Any repair works other than the operations outlines in this Instruction Manual is allowed only if STI S.r.l. authorises it.</p>

10.1 Field activities

During the start-up of the CO 3-way pneumatic valve:

- check that the pressure and quality of the supply fluid (filtering degree, dehydration, etcetera) are as prescribed;
- check if the operating condition are as prescribed;
- check that there are no leaks from the pneumatic connections;
- check that there are no leaks from the CS / SE quick exhaust body;
- remove all rust on the CS / SE quick exhaust surfaces;
- repair paint-coat that has been damaged, in accordance with the applicable painting specifications;
- perform a complete functional test.

10.2 Residual Risks

Reasonably foreseeable misuse:

- risk due to movements of loads during transport and installation;
- crushing during transport and installation;
- installation in ambient with not planned conditions;
- metal temperature at high or very low values as consequence of ambient temperature as to be considered as a risk of person injury in case of contact;
- insert incorrect motive fluid into the system;
- supply pressure out of planned range;
- emissions of hazardous substances where dangerous gases are used as motive fluid.

11 MAINTENANCE

<p>Warning</p> 	<p>The following instructions must be respected:</p> <ul style="list-style-type: none">- operations must be carried out only by skilled operators (STI operators or operators qualified by STI are recommended);- always wear protective clothing, gloves, and eyewear to prevent personal injury. Check with your process or safety engineer for any additional measures that must be taken to protect against process media.
---	--

Before any type of operation and/or maintenance is performed, make sure that:

- actuator, accessories and all connected equipment are not under pressure and in safe conditions;
- fluid supply, power or other energy sources and signals are disconnected;
- actuator is free from any mechanism able to move.

11.1 Periodic Inspections and maintenance

Periodic visual inspections are recommended. The user shall:

- plan and provide for a periodic cleaning/maintenance program that will maintain the external surface of the CS / SE quick exhaust free from excessive layer of dust;

11.2 Extraordinary maintenance

In case of extraordinary maintenance, following malfunction and related troubleshooting, proceed as written in Section 13.

12 PARTS LIST GENERAL ASSEMBLY

12.1 CS / SE

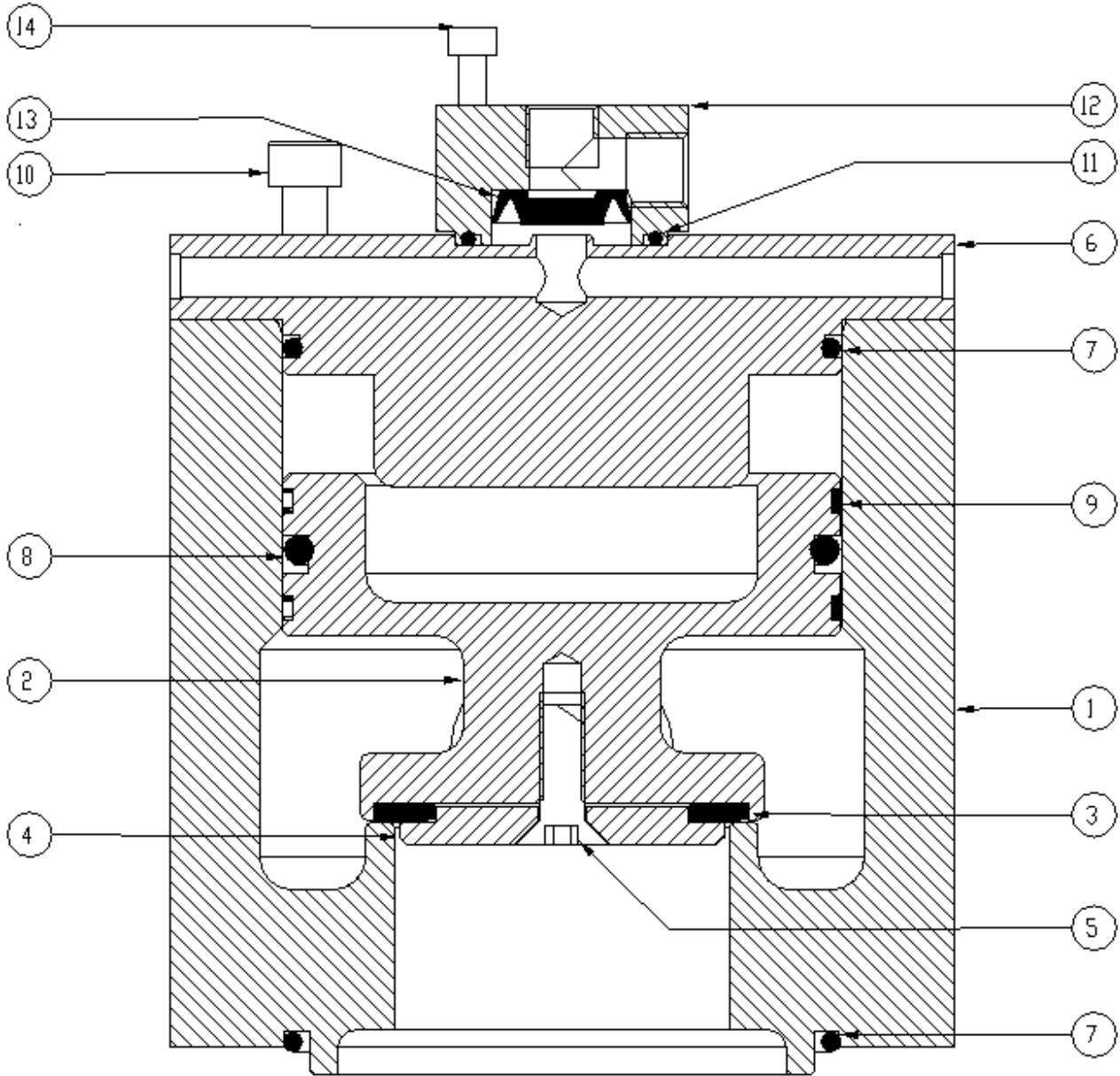



Figure 9 – CS / SE quick exhaust

POS.	Q.TY'	DESCRIPTION
1	1	BODY
2	1	PLUG
3	1	GASKET
4	1	COVER
5	1	SCREW TSPEI
6	1	VALVE COVER
7	2	SEALING RING
8	1	SEALING RING
9	2	SLIDING RING
10	4	SCREW TCEI
11	1	SEALING RING
12	1	PILOT CAP
13	1	DIAPHRAGM PLUGGER
14	2	SCREW TCEI-

Figure 10 – CS / SE quick exhaust

13 TROUBLESHOOTING

EVENT	POSSIBLE CAUSE	REMEDY
CS / SE quick exhaust doesn't move	Lack of pneumatic supply	Check supply line
	Low supply pressure	Adjust supply pressure
	Pneumatic circuit failure	Check pneumatic circuit
	Damaged internal parts (spring, diaphragm, etc..)	Call STI S.r.l.
Leakages from CS / SE quick exhaust	Deterioration and/or damage of gasket	Replace the gaskets
	Deterioration and/or damage of the parts with pressure inside	Call STI S.r.l.
	Incorrect screws tighten	Call STI S.r.l.
Leakages from pneumatic circuit	The nuts of pipe fittings are not tighten enough	Tighten the nuts
	Pneumatic circuit failure	Check pneumatic circuit

Important 	<p>If another event happens or another possible cause of the above events has been detected, call STI S.r.l.</p>
--	--

14 SPARE PARTS

Spare parts can be sent to the customer if required. Contact STI S.r.l.

15 DISASSEMBLING

Important 	<p>The customer can disassemble the CS / SE quick exhaust only for gaskets/grease replacement (see Section 11). In other cases, the disassembling is not allowed if it is not authorized by STI.</p>
---	--

16 DECOMMISSIONING

<p>Warning</p> 	<p>The following instructions must be respected:</p> <ul style="list-style-type: none"> - operations must be carried out only by skilled operators; - always wear protective clothing, gloves, and eyewear to prevent personal injury. Check with your process or safety engineer for any additional measures that must be taken to protect against process media.
---	--

<p>Important</p> 	<p>Check local authority regulation before disposal.</p>
---	--

SUBJECT	HAZARDOUS	RECYCABLE	DISPOSAL
Metals	No	Yes	Use licensed recyclers
Plastics	No	Yes	Use specialist recyclers
Rubber (seals, o-rings)	Yes	No	May require special treatment before disposal, use specialist waste disposal companies
Oil and grease	Yes	Yes	May require special treatment before disposal, use specialist waste disposal companies

IMI STI - Headquarters

Via Dei Caravaggi 15
24040 Levate (BG)
Italy

Tel. +39 035 2928.2
Fax +39 035 2928.247

IMI STI – Sales office

Via San Francesco 18
29017 Fiorenzuola d'Arda (PC)
Italy

Tel. +39 035 2928.2
Fax +39 0523 1715.295

IMI Critical Engineering

Lakeside, Solihull Parkway
Birmingham Business Park
Birmingham B37 7XZ
United Kingdom

Tel. +44 (0)121 717 3700
Fax +44 (0)121 717 3701

www.stiactuation.com
www.imi-critical.com
imisti.sales@imi-critical.com