

ER – EXHAUST REGULATOR

INSTRUCTION MANUAL 2097

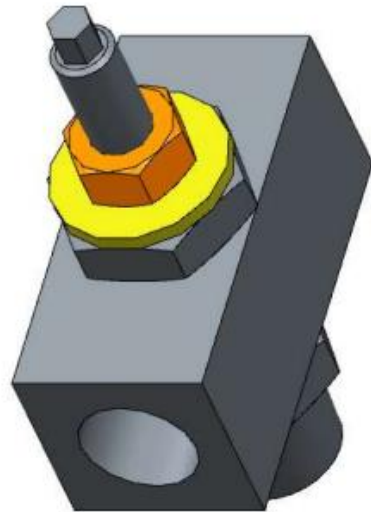

Engineering
GREAT Solutions

05/10/2022	02	<i>Added dust certifications table 7 and IECEx label section 4.1</i>	<i>M.Oberti</i>	<i>N.Zenoni</i>
09/12/2021	01	<i>Revised</i>	<i>M.Oberti</i>	<i>N.Zenoni</i>
Date	Revision	Description	Compiled	Approved

IMI STI S.r.l has taken every care in collecting and verifying the documentation contained in this Instruction Manual. The information herein contained are reserved property of IMI STI S.r.l

INDEX

1	GENERAL INFORMATION	5
1.1	GENERAL WARNING	5
1.2	GENERALITIES.....	5
1.3	MANUFACTURER.....	5
1.4	TERMS AND CONDITIONS.....	5
1.5	MANUFACTURER'S LIABILITY	6
1.6	APPLICABLE STANDARDS AND DIRECTIVES	6
1.7	SYMBOLOLOGY USED.....	7
1.8	SIGNS OF WARING.....	7
1.9	SIGNS OF OBLIGATION.....	7
2	DEVICE DESCRIPTION	8
2.1	GENERAL DESCRIPTION	8
2.2	MODEL SELECTION.....	9
3	TECHNICAL DATA.....	11
4	CERTIFICATION.....	12
4.1	LABEL.....	ERRORE. IL SEGNALIBRO NON È DEFINITO.
5	USER PROCEDURES	13
5.1	TRANSPORT.....	13
5.2	RECEPTION.....	13
5.3	STORAGE	13
5.4	INSTALLATION	13
5.5	CHECKS TO BE PERFORMED BEFORE INSTALLATION	13
5.6	DIMENSIONAL DRAWING.....	14
5.7	PNEUMATIC CONNECTIONS.....	14
5.8	EARTHING CONNECTIONS.....	14
5.9	DISASSEMBLING.....	14
6	OPERATION AND USE	15
6.1	OPERATION DESCRIPTION.....	15
6.2	PRODUCT TYPE 55.....	16
6.3	TYPE 56.....	18
6.4	TYPE 57.....	20
6.5	TYPE 58.....	22
6.6	TYPE 59.....	24
6.7	TYPE 60.....	26
6.8	TYPE 61.....	28
6.9	INTENDED USE	30

6.10	REASONABLY FORSESEEABLE MISUSE.....	30
6.11	OPERATING LIMITS.....	30
6.12	RESIDUAL RISKS.....	30
7	INSTRUCTION FOR THE OPERATOR.....	31
8	MAINTENANCE.....	32
8.1	PERIODIC INSPECTIONS.....	32
8.2	SPECIAL MAINTENANCE.....	32
8.3	REPAIRS.....	32
9	TROUBLESHOOTING.....	33
10	DECOMMISSIONING.....	34

1 GENERAL INFORMATION

1.1 GENERAL WARNING



This Instruction Manual is an integral part of the machine, it should be carefully read before carrying out any operation and it should be kept for future references. The operators shall adopt the safety precautions required by the country where the product is installed.

1.2 GENERALITIES

IMI STI products are conceived, manufactured and controlled according to the Quality Control System in compliance with EN ISO 9001 International Standard.

1.3 MANUFACTURER

According to Machinery Directive 2006/42/EC, the Manufacturer of the described product is IMI STI.

IMI STI, Via Dei Caravaggi 15
24040 Levate, Bergamo, Italy
Tel. +39 035 29282
Fax +39 035 2928247
imisti.sales@imi-critical.com
sti.support@imi-critical.com

1.4 TERMS AND CONDITIONS

IMI STI guarantees each single product to be without defects and to be conform to current goods specifications. Unless otherwise stated on the purchased order, the warranty period is one year from the date of installation by the user, or eighteen months from the date of shipment to the first user, whichever occurs first, and considering that:

- the warranty does not cover products which have been subject to improper storage, improper installation, misuse, corrosion, or which have been modified or repaired by unauthorised personnel (it is not advisable that customer or end users modify the device characteristics);
- the warranty does not cover special products or components not covered by warranty in their turn by subcontractors.

1.5 MANUFACTURER'S LIABILITY

IMI STI declines all liability in the event of:

- the use of the product does not comply with local legislation on safety at work;
- disregard or incorrect application of the instructions provided on the product label and/or in the instruction manual;
- incorrect installation and/or use of the product;
- modifications without STI's authorisation and/or work done on the unit by unqualified or unsuitable persons.

1.6 APPLICABLE STANDARDS AND DIRECTIVES

2006/42/EC	Machinery Directive
2014/68/EU	Pressure Equipment Directive (PED)
EN ISO 80079-36	Explosive atmospheres. Non-electrical equipment for explosive atmospheres. Basic method and requirements
EN ISO 80079-37	Explosive atmospheres. Non-electrical equipment for explosive atmospheres. Non-electrical type of protection constructional safety "c", control of ignition sources "b", liquid immersion "k"
EN ISO 12100	Safety of machinery. General principles for design. Risk assessment and risk reduction
EN 60079-0	Explosive atmospheres - Part 0: Equipment - General requirements
EN 1127-1	Explosive atmospheres - Explosion prevention and explosion protection - Part 1
EN ISO 9001	Quality Management Systems. Requirements

Table 1

This product is designed in accordance with the applicable International Standards and Directives, but the following regulations must be observed in any case:

- general and safety regulations;
- plant specific regulations and requirements;
- proper use of personal devices, protective devices (glasses, clothing, gloves, etc), tools and transport equipment.

1.7 SYMBOLOGY USED

1.8 SIGNS OF WARNING

Be careful where the following symbols are shown. They indicate a potentially hazardous situation and they warn that if the steps are not properly performed, they may cause serious injury, death or long term risks to health of exposed persons.



 <p>General Danger</p>	 <p>Crushing hazard</p>	 <p>Power supply hazard</p>
---	--	---

Table 2

1.9 SIGNS OF OBLIGATION

Be careful where the following symbols are shown. They indicate an obligation that must be respected.

 <p>General obligation</p>	 <p>Obligation to wear protective clothing.</p>	 <p>Obligation to wear protective footwear.</p>	 <p>Obligation to wear a helmet.</p>	 <p>Obligation to protect your eyes.</p>	 <p>Obligation to protect your hearing.</p>
---	--	--	---	---	--

Table 3

2 DEVICE DESCRIPTION

2.1 GENERAL DESCRIPTION

The exhaust regulator ER is an adjustable restrictor which limits the exhaust air flow of a pneumatic component. The valve flow rate is adjustable by the setting screw, consequently it is possible to increase or decrease the actuator stroking time. The air can be exhaust from the actuator directly to the atmosphere or can be exhaust to the breather actuator cylinder chamber when it is used in a closed breather loop system.

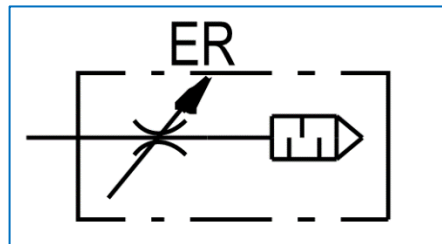

Figure 1

2.2 MODEL SELECTION



S - SIZE	
04	1/4"
08	1/2"
16	1"
25	1"1/2

M - MATERIAL	
S0	Stainless Steel SS316
S1	Stainless Steel SS316 (Copper Free Execution)
A0	Aluminum
A1	Aluminum (Copper Free Execution)

P - PAINTING	
00	Not Painted
01	Standard Painting Cycle (CVA.01)
99	Customized Painting

T - TEMPERATURE RANGE	
H	-20°C / +85°C
S	-20°C / +70°C
L	-40°C / +70°C
E	-55°C / +70°C
U	-60°C / +100°C

C - CONNECTIONS	
2C	Supply / Exhaust
4E	Supply / Exhaust
6M	Supply / Exhaust
8T	Supply / Exhaust

O - OPTIONS	
C	Collected Exhaust
A	Free Exhaust

Table 4

Below is the legend regarding the model selection relating to the "C - CONNECTIONS" section

Legend NPT/GAS		Legend HOLES	
1	1/8	A	0mm
2	1/4	B	0mm-5mm
3	3/8	C	12mm-17mm
4	1/2	E	21mm-25mm
5	3/4	G	26mm-31mm
6	1	M	33mm-34mm
7	1 1/4	P	Plug-in
8	1 1/2	T	40mm-45mm
9	2	V	46mm
		W	54mm-56mm
		X	56,1mm-62mm
		Y	69mm-100mm
		Z	160mm-270mm

Table 5



Not all product configurations are available.
For a better product selection, please contact imisti.sales@imi-critical.com or sti.support@imi-critical.com
For existing model see [par. 9.2](#)

3 TECHNICAL DATA

SIZE	1/4" 1/2" 1" 1"1/2
BODY MATERIAL	Stainless steel 316 Alluminium
EXTERNAL PAINTING	Not painted Standard cycle painting (CVA.01) OPTION CUSTOMIZED PAINTING
EXTERNAL SURFACE TREATMENT	Anodized
GASKET MATERIAL	Nbr Viton Fluorosilicone
WORKING PRESSURE p min [Bar]	3
WORKING PRESSURE p max [Bar]	12
DESIGN PRESSURE p des [Bar]	12
WORKING TEMPERATURE T min [°C]	-20
WORKING TEMPERATURE T max [°C]	+85
EXTENDED TEMPERATURE T min [°C]	-60
EXTENDED TEMPERATURE T max [°C]	+100
STORAGE TEMPERATURE T min [°C]	-40
STORAGE TEMPERATURE T max [°C]	+95
SUPPLY 1 PNEUMATIC CONNECTIONS	1/4" 1/2" 1" 1"1/2
EXHAUST PNEUMATIC CONNECTIONS	12mm-17mm 21mm-25mm 33mm-34mm 40mm-45mm
GREASE	-
THREAD LOCKER	-
ADHESIVE	-
FLUID	Air
CV IN MAX	-
CV OUT MAX	1,1 1,4 3 3,8 10 13
CV BYPASS MAX	-
INTERNATIONAL PROTECTION (IP)	-
LIFETIME	30 years

Table 6

- Tubing with diameter equal to 8mm or 3/8" are recommended as pilot tubing;
- Tubing with diameter greater than the product thread connection size are recommended as supply and exhaust tubing;

4 CERTIFICATION

	CERTIFICATION	TYPE OF CERTIFICATION	CERTIFICATE NUMBER
1	ATEX	Ex h IIB/IIC T6T5/T4 Ex h IIIC T85°C/T100°C/T135°C Db	INERIS-CERN 037358/22
2	IECEX	Ex h IIB/IIC T6/T5/T4 Ex h IIIC T85°C/T100°C/T135°C Db	INE 19.0026
3	UKEX	Ex h IIB/IIC T6T5/T4 Ex h IIIC T85°C/T100°C/T135°C Db	G104964813

Table 7

4.1 LABEL

A label is attached on the product when the device is sold alone. When the product is mounted on a machinery (like an actuator) or it is sold as spare part, the label is not attached. It is forbidden to modify the information and the marks without previous written authorization by IMI STI.

Labels containing the ATEX marking according to Directive 2014/34/EU Annex II paragraph 1, comma 1.0.5 and CE marking according to Directive 2014/34/EU Annex VIII paragraph 4, comma 4.1 and IECEx marking according to EN ISO 80079-36 Section 11:

1. Label ATEX/IECEX IIC: IMI STI drawing FD83746_01
2. Label ATEX/IECEX IIB: IMI STI drawing FD83746_02

Label containing the specific marking of explosion protection according to SI 2016 No. 1107 and UKCA marking according to The Product Safety and Metrology etc. (Amendment etc.) (EU Exit) Regulations 2019:

3. Label UKEX IIC: IMI STI drawing FD83746_03
4. Label UKEX IIB: IMI STI drawing FD83746_04

5 USER PROCEDURES



Not performing the following procedures will invalidate the product warranty

5.1 TRANSPORT



Always wear protective clothing, gloves, and eyewear to prevent personal injury. The lifting and handling shall be made by qualified staff and in compliance with the laws and valid provisions.

5.2 RECEPTION

Check if the model corresponds with the one reported on the purchase order and if no defects are visible on the product. Product related documents are furnished with documents accompanying the machinery where the product is mounted on. If the product is sold alone, contact IMI STI or download the documentation from IMI STI web site.

5.3 STORAGE

To maintain the product in perfect condition, proper attention must be observed to preserve the product during the storage period. Remember to:

- place the product on a wood surface pallet or on metallic support, avoiding direct contact with the ground;
- protect the product with appropriate covering;
- make sure that plastic plugs are present on the pneumatic connections. If stored outdoor, replace plastic plugs with metal plugs that guarantee perfect tightness;
- keep the product protected from weather conditions.

5.4 INSTALLATION



Always wear protective clothing, gloves, and eyewear to prevent personal injury. Check with your process or safety engineer for any additional measures that must be taken to protect against process media.

5.5 CHECKS TO BE PERFORMED BEFORE INSTALLATION

To allow a correct installation of the product, verify that the product outer surface is free from dust and dirt; if not, clean it and remove anything that might prevent a correct installation. Then, check if the coupling dimensions meet the specified ones and prepare all the necessary tools for the assembly and setting of the unit.

5.6 DIMENSIONAL DRAWING

For dimensional drawing , section and spare parts , see [chapter 6.0](#)

5.7 PNEUMATIC CONNECTIONS



**Check that the supply pressure are lower than the product design pressure.
Use appropriate pipes and fittings (type, rating, material and dimensions).
The connection shall be made by qualified staff.**

To guarantee the best performances, follow the

- properly deburr the ends of rigid pipes;
- properly clean the interior of pipes sending through them plenty of the supply fluid used in the system;
- mould and fasten the connection pipes in order to avoid overstress on the connection parts and to avoid loosening of the threaded connections;
- use the recommended quantity of pipe sealant, only on male threads (no-hardening sealant is strongly recommended);
- make the connections according to the machinery (i.e. actuator) pneumatic diagram;
- check that no leakage occurs from pneumatic connections. If necessary, tighten the fittings;
- collect tubing as indicated in the technical data table.

5.8 EARTHING CONNECTIONS

The earthing connection is guaranteed through the product fixing screws on the machinery and/or through the pneumatic fittings. If, for any reason, no earthing connection is guaranteed, ensure it by connect the product (or the machinery where the product is mounted) to earth.

5.9 DISASSEMBLING



**Before starting any disassembly operations, it is mandatory to disconnect the pneumatic power and exhaust the product (no fluid under pressure inside the product, fittings, tubing).
The staff must be qualified for the required operation.**

6 OPERATION AND USE



It is severely forbidden to use the product for purpose or application other than those for which it was designed and here above specified.

The product contains fluid under pressure: be careful when using it.

6.1 OPERATION DESCRIPTION

In the following paragraphs you will find information regarding the dimensional drawings, , part list and the list with all the models currently available for each type of accessory with the relative spare parts.

6.2 PRODUCT TYPE 55

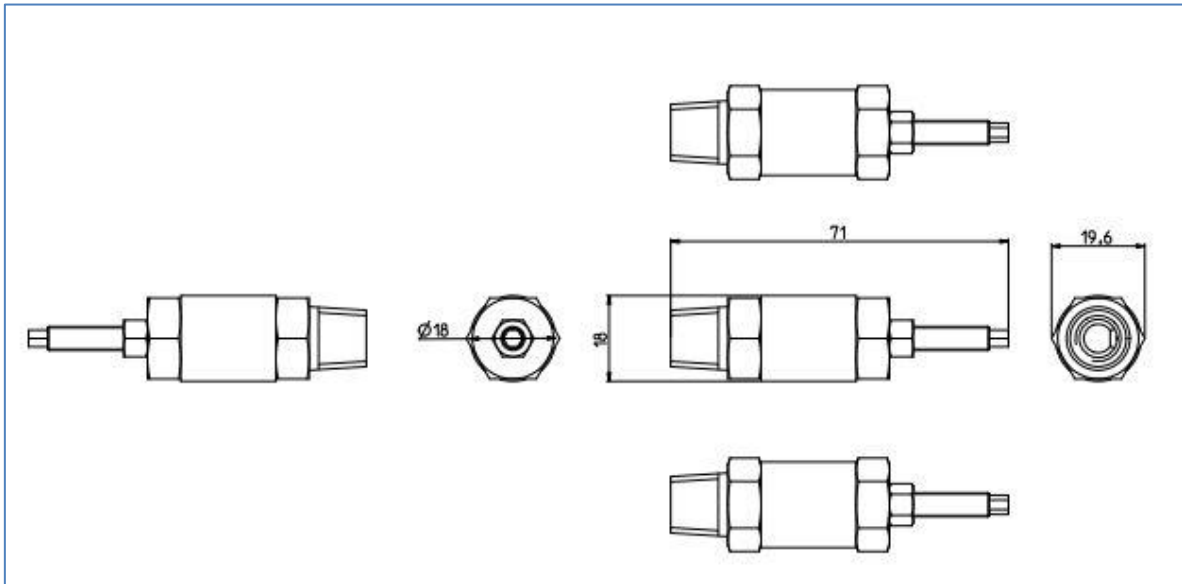

Figure 2 – Dimensional drawing

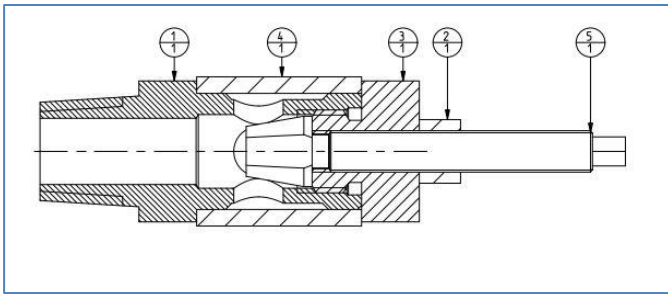

Figure 3 - Section

PART LIST		
Pos	Qty	Description
1		
2		
3		
4		
5		

Table 8 – Part List

EXISTING PRODUCTS AND SPARE PARTS			
MODEL	PART NUMBER	SPARE	POSITION
ER-04-S1-00-H-2C-A	112639	112639	ALL
ER-04-S1-00-S-2C-A	112639	112639	ALL
ER-04-S1-00-L-2C-A	112639	112639	ALL
ER-04-S1-00-E-2C-A	112639	112639	ALL
ER-04-S1-00-U-2C-A	112639	112639	ALL

Table 9 – Existing product and spare parts



The previous models are those currently available.
 For further models refer to the model selection in **par. 2.2** , contact imisti.sales@imi-critical.com or sti.support@imi-critical.com.

6.3 TYPE 56

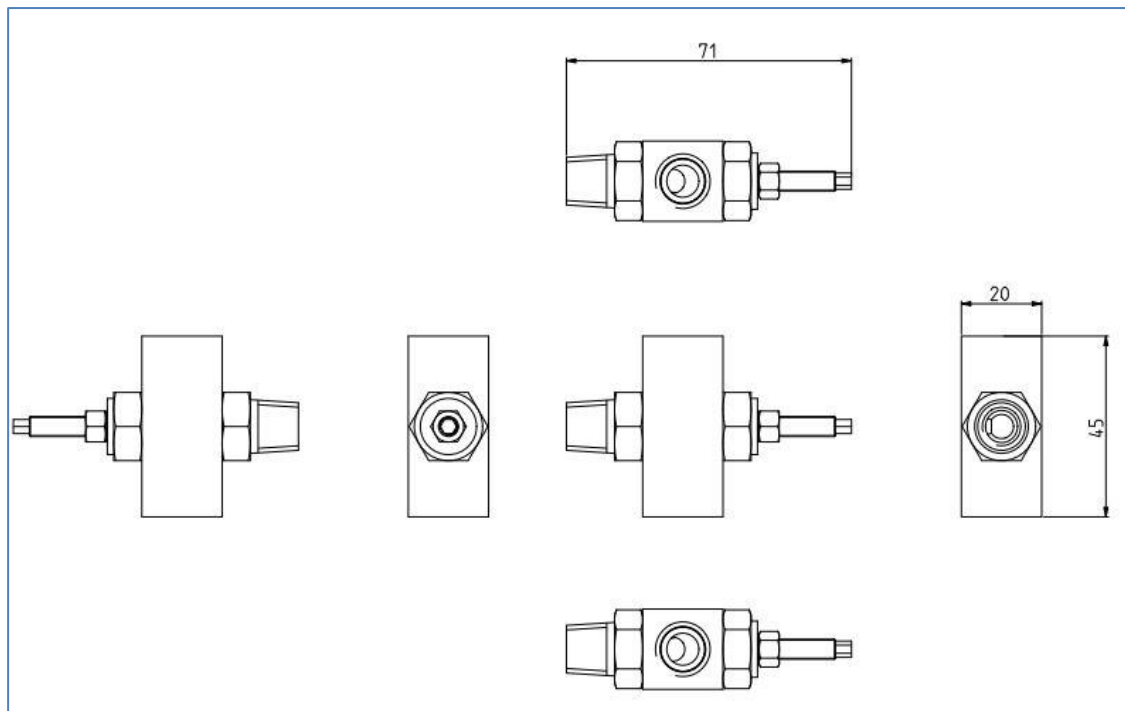

Figure 4 – Dimensional drawing

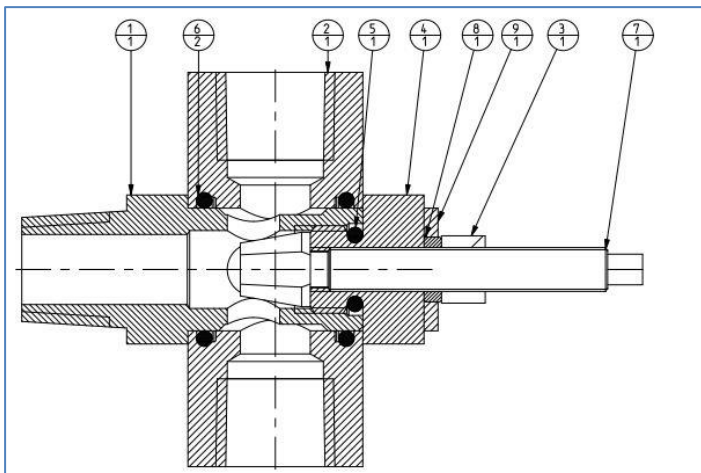



Figure 5 - Section

PART LIST		
Pos	Qty	Description
1		
2		
3		
4		
5		
6		
7		
8		
9		

Table 10 – Part List

EXISTING PRODUCTS AND SPARE PARTS			
MODEL	PART NUMBER	SPARE	POSITION
ER-04-S1-00-H-2C-C	119907	119907	ALL
ER-04-S1-00-S-2C-C	119907	119907	ALL
ER-04-S1-00-L-2C-C	119907	119907	ALL
ER-04-S1-00-E-2C-C	119907	119907	ALL

Table 11 – Existing product and spare parts

	<p>The previous models are those currently available. For further models refer to the model selection in <u>par. 2.2</u> , contact <u>imisti.sales@imi-critical.com</u> or <u>sti.support@imi-critical.com</u>.</p>
---	---

6.4 TYPE 57

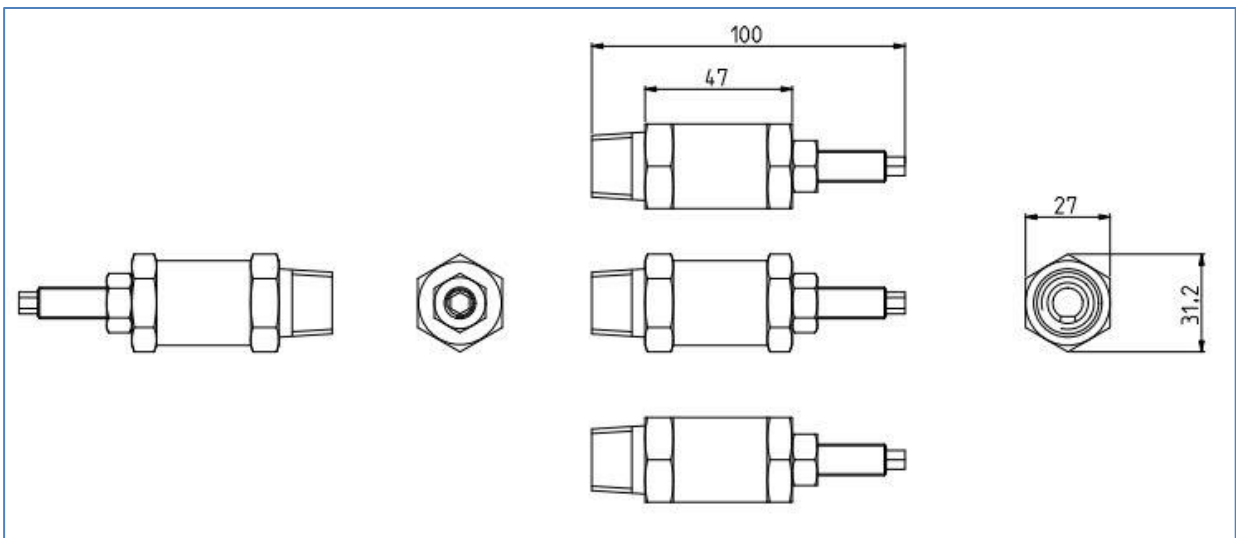

Figure 6 – Dimensional drawing

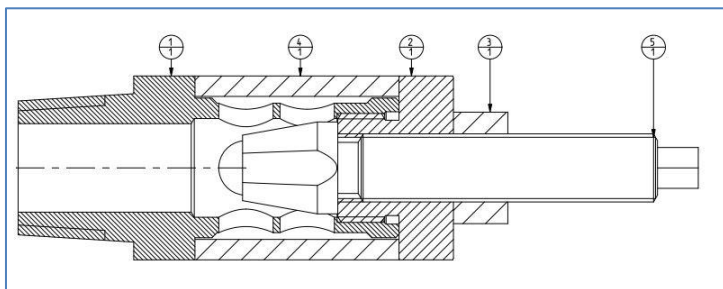

Figure 7 - Section

PART LIST		
Pos	Qty	Description
1		
2		
3		
4		
5		

Table 12 – Part List

EXISTING PRODUCTS AND SPARE PARTS			
MODEL	PART NUMBER	SPARE	POSITION
ER-08-S1-00-H-4E-A	113370	113370	ALL
ER-08-S1-00-S-4E-A	113370	113370	ALL
ER-08-S1-00-L-4E-A	113370	113370	ALL
ER-08-S1-00-E-4E-A	113370	113370	ALL
ER-08-S1-00-U-4E-A	113370	113370	ALL

Table 13 – Existing product and spare parts



The previous models are those currently available.
 For further models refer to the model selection in par. 2.2 or contact imisti.sales@imi-critical.com or sti.support@imi-critical.com.

6.5 TYPE 58

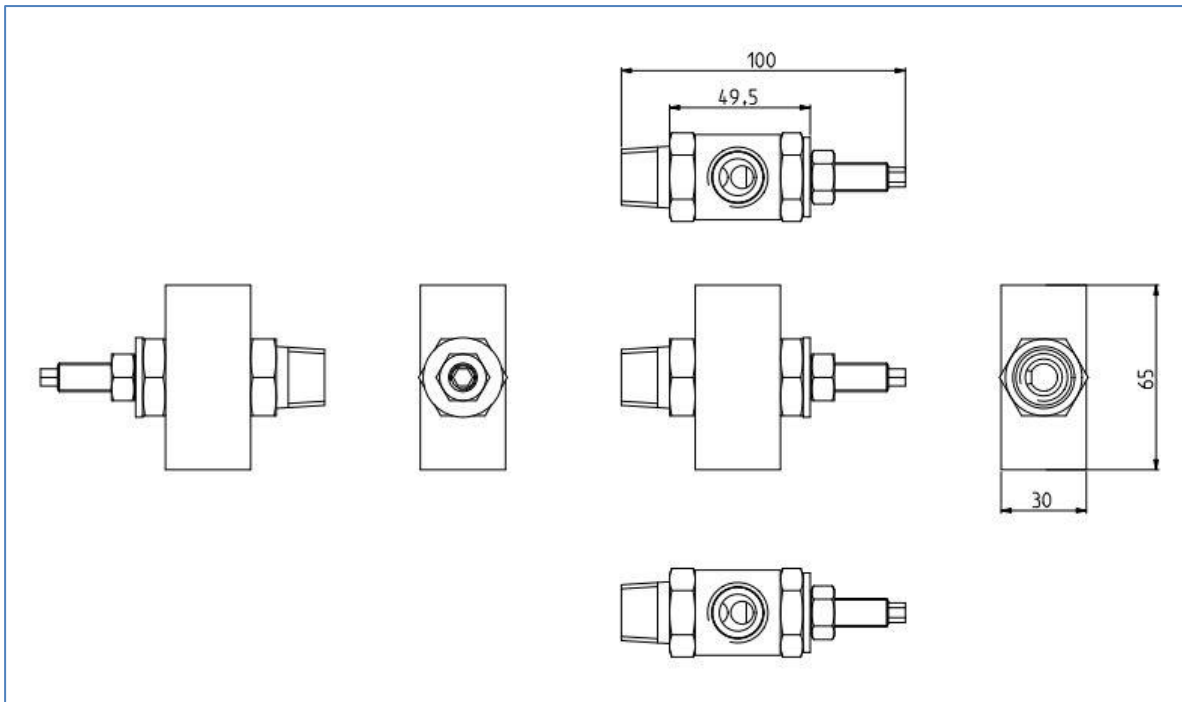

Figure 8 – Dimensional drawing

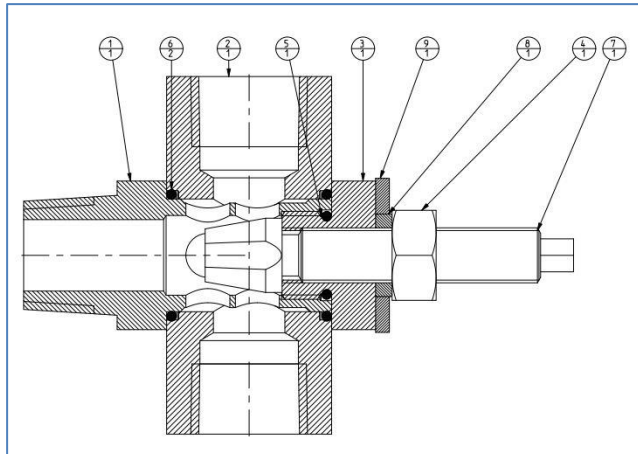



Figure 9 - Section

PART LIST		
Pos	Qty	Description
1		
2		
3		
4		
5		
6		
7		
8		
9		

Table 14 – Part List

EXISTING PRODUCTS AND SPARE PARTS			
MODEL	PART NUMBER	SPARE	POSITION
ER-08-S1-00-H-4E-C	123835	123835	ALL
ER-08-S1-00-S-4E-C	123835	123835	ALL
ER-08-S1-00-L-4E-C	123835	123835	ALL
ER-08-S1-00-E-4E-C	123835	123835	ALL

Table 15 – Existing product and spare parts

	<p>The previous models are those currently available. For further models refer to the model selection in par. 2.2 or contact imisti.sales@imi-critical.com or sti.support@imi-critical.com.</p>
---	---

6.6 TYPE 59

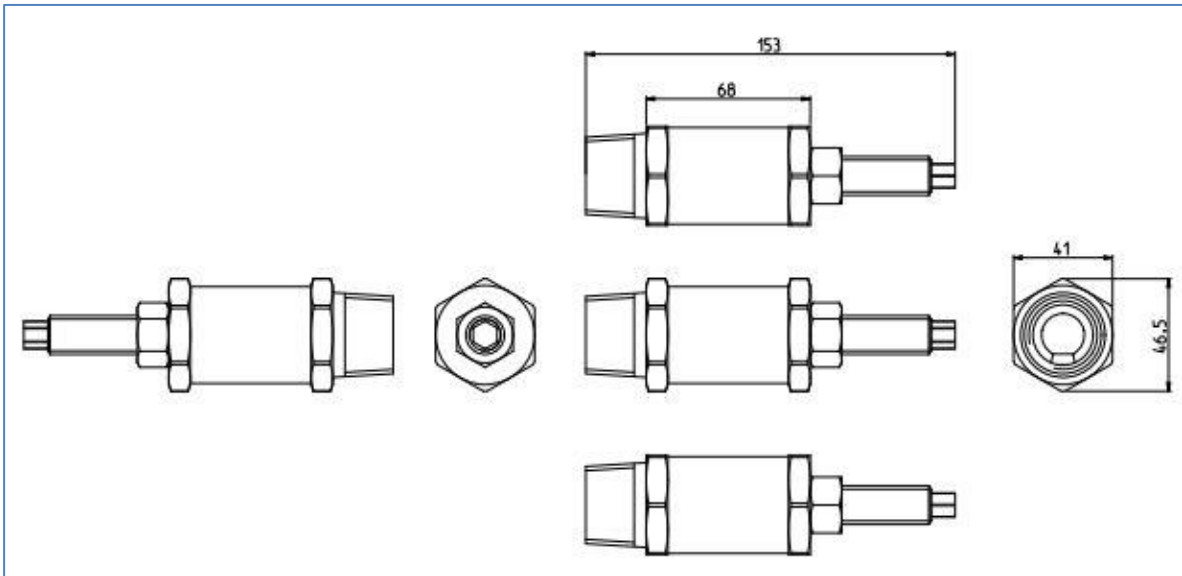

Figure 10 – Dimensional drawing

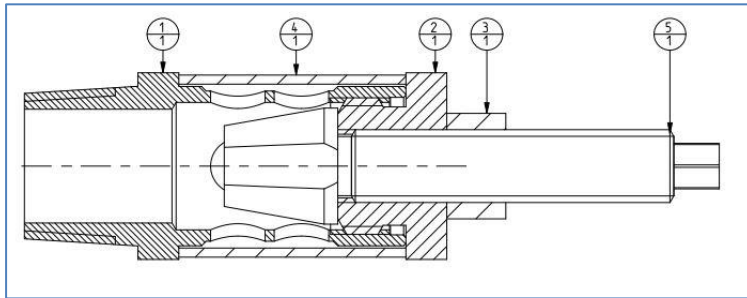

Figure 11 - Section

PART LIST		
Pos	Qty	Description
1		
2		
3		
4		
5		

Table 16 – Part List

EXISTING PRODUCTS AND SPARE PARTS			
MODEL	PART NUMBER	SPARE	POSITION
ER-16-S1-00-H-6M-A	111115	111115	ALL
ER-16-S1-00-S-6M-A	111115	111115	ALL
ER-16-S1-00-L-6M-A	111115	111115	ALL
ER-16-S1-00-E-6M-A	111115	111115	ALL
ER-16-S1-00-U-6M-A	111115	111115	ALL

Table 17 – Existing product and spare parts



The previous models are those currently available.
For further models refer to the model selection in par. 2.2 or contact imisti.sales@imi-critical.com or sti.support@imi-critical.com.

6.7 TYPE 60

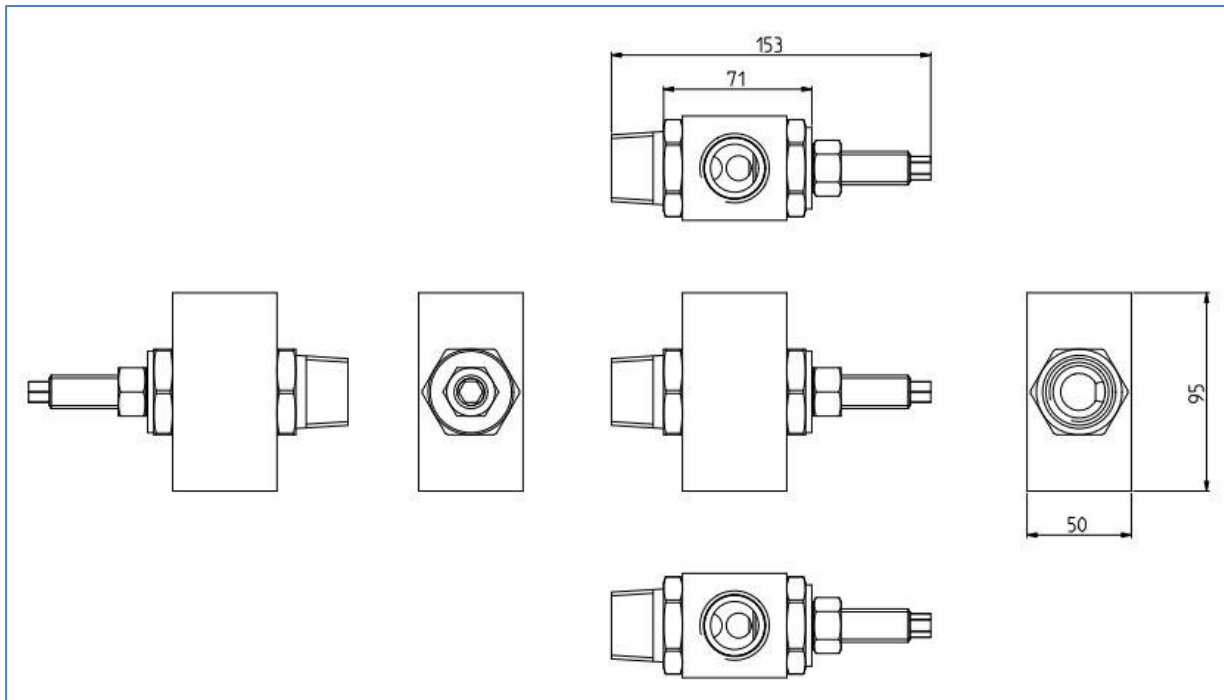
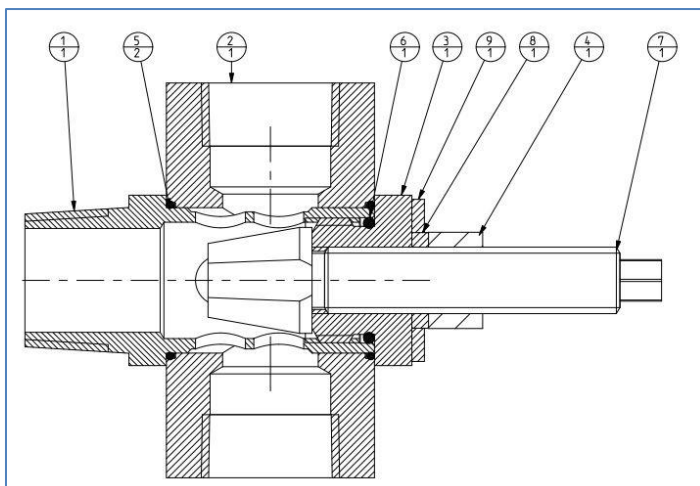

Figure 12 – Dimensional drawing



PART LIST		
Pos	Qty	Description
1		
2		
3		
4		
5		
6		
7		
8		
9		

Table 18 – Part List

Figure 13 - Section

EXISTING PRODUCTS AND SPARE PARTS			
MODEL	PART NUMBER	SPARE	POSITION
ER-16-S1-00-H-6M-C	131351	131351	ALL
ER-16-S1-00-S-6M-C	131351	131351	ALL
ER-16-S1-00-L-6M-C	131351	131351	ALL
ER-16-S1-00-E-6M-C	131351	131351	ALL

Table 19 – Existing product and spare parts

	<p>The previous models are those currently available. For further models refer to the model selection in par. 2.2 or contact imisti.sales@imi-critical.com or sti.support@imi-critical.com.</p>
---	--

6.8 TYPE 61

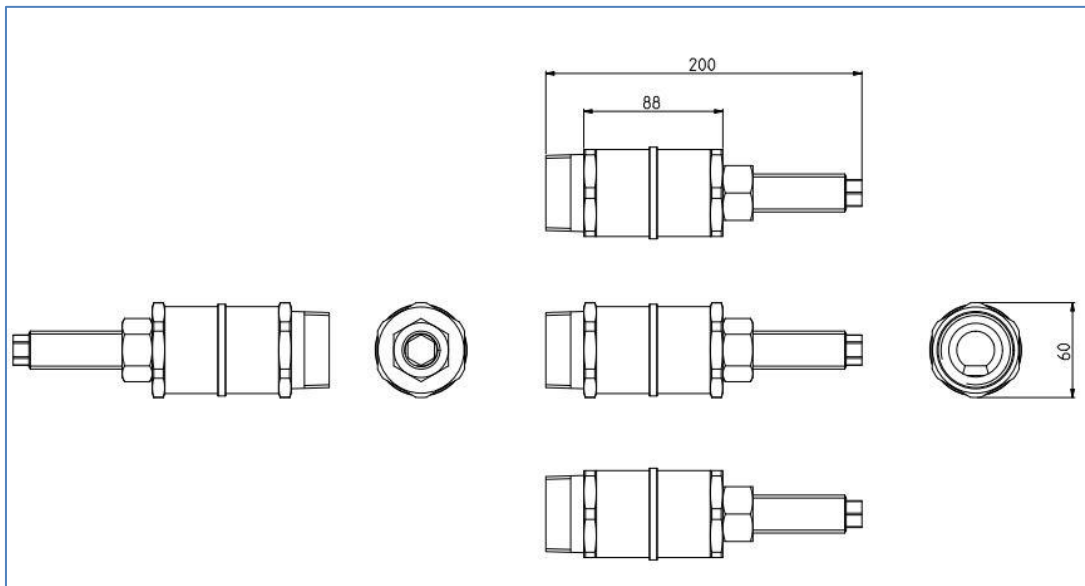

Figure 14 – Dimensional drawing

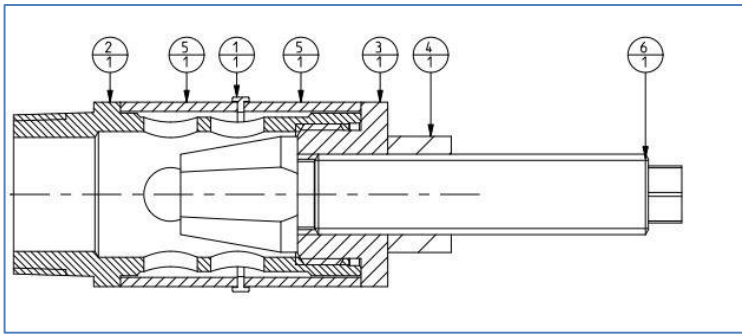

Figure 15 - Section

PART LIST		
Pos	Qty	Description
1		
2		
3		
4		
5		
6		
7		

Table 20 – Part List

EXISTING PRODUCTS AND SPARE PARTS			
MODEL	PART NUMBER	SPARE	POSITION
ER-25-S1-00-H-8T-A	123277	123277	ALL
ER-25-S1-00-S-8T-A	123277	123277	ALL
ER-25-S1-00-L-8T-A	123277	123277	ALL
ER-25-S1-00-E-8T-A	123277	123277	ALL
ER-25-S1-00-U-8T-A	123277	123277	ALL

Table 21 – Existing product and spare parts



**The previous models are those currently available.
For further models refer to the model selection in par. 2.2 or contact
imisti.sales@imi-critical.com or sti.support@imi-critical.com.**

6.9 INTENDED USE

IMI STI will not be liable for any possible damage or physical injury resulting from use in other than the designated applications or by lack of care during installation, operation, adjustment or maintenance. Such risks lie entirely with the user.

Considering that IMI STI has no direct control over applications, operation or maintenance conditions, it is the operator's responsibility to comply with all applicable safety rules: it is the sole responsibility of the operator to ensure that the local health and safety regulations are adhered to.

Depending on the specific working conditions, additional precautions may be requested.

Please inform IMI STI if you face unsafe situations not described in this Instruction Manual.

6.10 REASONABLY FORESEEABLE MISUSE

A short list of reasonably foreseeable misuse:

- installation in ambient with not planned conditions (i.e. climatic conditions different from the specified conditions);
- incorrect fluid under pressure inside the product;
- supply pressure out of required range.

6.11 OPERATING LIMITS

The product label and/or this manual indicate the main operating conditions of this product.

6.12 RESIDUAL RISKS

A short list of possible risks:

- risk due to movements of loads during mounting phase;
- crushing during assemblage servicing;
- extreme high or low surface temperature, as consequence of ambient temperature, has to be considered a risk of person injury in case of contact;
- hazardous fluid emission (i.e. when natural gas is used as fluid under pressure).

7 INSTRUCTION FOR THE OPERATOR

During the start-up of the product, proceed as follows:

- check that the pressure and quality of the air supply (filtering degree, dehydration) are as prescribed;
- check that there are not leaks in the pneumatic connections. If necessary, tighten the fittings;
- set the product according the schematic diagram.

8 MAINTENANCE

8.1 PERIODIC INSPECTIONS



Take care that a build-up of dust or dirt on the product can inhibit cooling and contribute to increase surface temperature. The user should plan and provide for a periodic cleaning / maintenance program that will maintain the external surface of the accessory free from excessive layer of dust.
Operation and maintenance shall be carried out by skilled staff.

Product disassembling and reassembling shall be carried out only by IMI STI authorized operators.

8.2 SPECIAL MAINTENANCE

The product does not need special maintenance considering standard applications. If special maintenance is required, send back the device to IMI STI.

Product disassembling and reassembling shall be carried out only by IMI STI authorized operators.



For the available part lists of each accessory refer to 6.2 and subsequent paragraphs or contact imisti.sales@imi-critical.com or sti.support@imi-critical.com.

8.3 REPAIRS

Repairs shall be carried out by authorized operators. When needed, send back the device to IMI STI for any repairing.

Product disassembling and reassembling shall be carried out only by IMI STI authorized operators.



For the available part lists of each accessory refer to 6.2 and subsequent paragraphs or contact imisti.sales@imi-critical.com or sti.support@imi-critical.com.

9 TROUBLESHOOTING

Event	Possible cause	Remedy
Do not work properly	Lack of pneumatic supply	Check supply line
	Low supply pressure	Adjust supply pressure
	Uncorrected by-pass stem adjustment	See Instruction for the operator
	Defective internal component (shutter, piston, ecc.)	Call IMI STI S.r.l.
Leakages on pneumatic circuits	Deterioration and/or damage to gasket and/or loosed fittings	Call IMI STI S.r.l.
	Damage to fittings	Call IMI STI S.r.l.

Table 22

10 DECOMMISSIONING

Subject	Hazardous	Recyclable	Disposal
Metals	No	Yes	Use licensed recyclers
Plastics	No	Yes	Use specialist recyclers
Rubber (seals and O-rings)	Yes	No	May require special treatment before disposal, use specialist waste disposal companies
Oil and grease	Yes	Yes	May require special treatment before disposal, use specialist waste disposal companies

Table 23



Before starting any disassembly operations, it is mandatory to disconnect the pneumatic power and exhaust the product (no fluid under pressure inside the product, fittings, tubing).

The staff must be qualified for the required operation.



**The product decommissioning shall be made by specialized operators
Check local authority regulation before disposal**

IMI STI - Headquarters

Via Dei Caravaggi 15
24040 Levate (BG)
Italy

Tel. +39 035 2928.2
Fax +39 035 2928.247

IMI Critical Engineering

Lakeside, Solihull Parkway
Birmingham Business Park
Birmingham B37 7XZ
United Kingdom

Tel. +44 (0)121 717 3700
Fax +44 (0)121 717 3701

www.IMI-STIactuation.com
www.imi-critical.com
imisti.sales@imi-critical.com