

# SHP

# Smart High-Performance Positioner

INSTRUCTION MANUAL 4056  
(HARDWARE)



  
*Engineering  
GREAT Solutions*

07/12/2023	01	General revision	M.Coffetti	N.Zenoni
21/11/2023	00	Issue	M.Coffetti	N.Zenoni
Date	Revision	Description	Compiled	Approved

*IMI STI S.r.l has taken every care in collecting and verifying the documentation contained in this Instruction Manual. The information herein contained are reserved property of IMI STI S.r.l*

# INDEX

<b>1</b>	<b>GENERAL INFORMATION .....</b>	<b>4</b>
1.1	GENERAL WARNING .....	4
1.2	GENERALITIES .....	4
1.3	MANUFACTURER .....	4
1.4	TERMS AND CONDITIONS.....	4
1.5	MANUFACTURER'S LIABILITY .....	5
1.6	APPLICABLE STANDARDS AND DIRECTIVES .....	5
1.7	SYMBOLGY USED .....	7
1.7.1	SIGNS OF WARNING.....	7
1.7.2	SIGNS OF OBLIGATION .....	8
<b>2</b>	<b>DEVICE DESCRIPTION .....</b>	<b>9</b>
2.1	GENERAL DESCRIPTION .....	9
2.2	MODEL SELECTION .....	10
<b>3</b>	<b>TECHNICAL DATA .....</b>	<b>12</b>
<b>4</b>	<b>CERTIFICATION.....</b>	<b>14</b>
4.1	LABELS AND MARKING .....	14
<b>5</b>	<b>USER PROCEDURES .....</b>	<b>15</b>
5.1	TRANSPORT.....	15
5.2	RECEPTION.....	15
5.3	STORAGE .....	15
5.4	INSTALLATION .....	16
5.5	CHECKS TO BE PERFORMED BEFORE INSTALLATION .....	17
5.6	DIMENSIONAL DRAWING.....	17
5.7	PNEUMATIC CONNECTIONS.....	17
5.7.1	PNEUMATIC CONNECTIONS TO ACTUATOR.....	18
5.8	ELECTRICAL CONNECTIONS.....	18
5.8.1	INTRINSICALLY SAFE VERSION.....	19
5.8.2	EXPLOSION PROOF VERSION.....	23
5.9	EARTHING CONNECTIONS.....	25
5.10	DISASSEMBLING .....	25
<b>6</b>	<b>OPERATION AND USE.....</b>	<b>26</b>
6.1	OPERATION DESCRIPTION.....	26
6.2	PRODUCT DESCRIPTION .....	26
6.2.1	SHP-Ix00xxxAx (I = INTRINSICALLY SAFE, A = ALLUMINIUM VERSION) .....	26
6.2.2	SHP-Ix00xxxSx (I = INTRINSICALLY SAFE, S = STAINLESS STEEL VERSION) .....	27
6.2.3	SHP-Dx00xxxAx (D = EXPLOSION PROOF, A = ALLUMINIUM VERSION) .....	27
6.2.4	SHP-Dx00xxxSx (D = EXPLOSION PROOF, S = STAINLESS STEEL VERSION) .....	28
6.2.5	CONTACTLESS REMOTED (ALLUMINIUM VERSION).....	28
6.2.6	CONTACTLESS REMOTED (STAINLESS STEEL VERSION).....	29
6.3	INTENDED USE .....	29
6.4	REASONABLY FORSESEEABLE MISUSE.....	29
6.5	OPERATING LIMITS.....	29
6.6	RESIDUAL RISKS.....	30

<b>7</b>	<b>INSTRUCTION FOR THE OPERATOR .....</b>	<b>31</b>
7.1	ELETTROMAGNETIC INTERFERENCE .....	31
7.2	PNEUMATIC SAFETY .....	31
7.3	ELECTRICAL SAFETY .....	32
<b>8</b>	<b>MAINTENANCE.....</b>	<b>33</b>
8.1	PERIODIC INSPECTIONS.....	33
8.2	SPECIAL MAINTENANCE .....	33
8.3	REPAIRS.....	33
<b>9</b>	<b>TROUBLESHOOTING.....</b>	<b>34</b>
<b>10</b>	<b>DECOMMISSIONING .....</b>	<b>35</b>

# 1 GENERAL INFORMATION

## 1.1 GENERAL WARNING



**This Instruction Manual is an integral part of the machine, it should be carefully read before carrying out any operation and it should be kept for future references. The operators shall adopt the safety precautions required by the country where the product is installed.**

## 1.2 GENERALITIES

IMI STI products are conceived, manufactured and controlled according to the Quality Control System in compliance with EN ISO 9001 International Standard.

## 1.3 MANUFACTURER

According to Machinery Directive 2006/42/EC, the Manufacturer of the described product is IMI STI.

IMI STI, Via Dei Caravaggi 15  
24040 Levate, Bergamo, Italy  
Tel. +39 035 29282  
Fax +39 035 2928247  
[imisti.sales@imi-critical.com](mailto:imisti.sales@imi-critical.com)  
[sti.support@imi-critical.com](mailto:sti.support@imi-critical.com)

## 1.4 TERMS AND CONDITIONS

IMI STI guarantees each single product to be without defects and to be conform to current goods specifications. Unless otherwise stated on the purchased order, the warranty period is one year from the date of installation by the user, or eighteen months from the date of shipment to the first user, whichever occurs first, and considering that:

- The warranty does not cover products which have been subject to improper storage, improper installation, misuse, corrosion, or which have been modified or repaired by unauthorised personnel (it is not advisable that customer or end users modify the device characteristics).
- The warranty does not cover special products or components not covered by warranty in their turn by subcontractors.

## 1.5 MANUFACTURER'S LIABILITY

IMI STI declines all liability in the event of:

- The use of the product does not comply with local legislation on safety at work.
- Disregard or incorrect application of the instructions provided on the product label and/or in the instruction manual.
- Incorrect installation and/or use of the product.
- Modifications without STI's authorisation and/or work done on the unit by unqualified or unsuitable persons.

## 1.6 APPLICABLE STANDARDS AND DIRECTIVES

EN ISO 12100	Safety of machinery - General principles for design. Risk assessment and risk reduction
EN ISO 9001	Quality Management Systems - Requirements
2014/35/UE	Directive for Low Voltage Equipment (LV)
2004/108/EC	Directive relating to the Electromagnetic Compatibility (EMC)
EN 60079-0	Explosive atmospheres - Part 0: Equipment - General requirements
EN 60079-1	Explosive atmospheres - Part 1: Equipment - Equipment protection by flameproof enclosures "d"
EN 60079-11	Explosive atmospheres - Part 11: Equipment - Equipment protection by intrinsic safety "i"
EN ISO 80079-36	Explosive atmospheres. Non-electrical equipment for explosive atmospheres. Basic method and requirements
EN ISO 80079-37	Explosive atmospheres. Non-electrical equipment for explosive atmospheres. Non-electrical type of protection constructional safety "c", control of ignition sources "b", liquid immersion "k"

**Table 1**

This product is designed in accordance with the applicable International Standards and Directives, but the following regulations must be observed in any case:

- General and safety regulations.
- Plant specific regulations and requirements.
- Proper use of personal devices, protective devices (glasses, clothing, gloves, etc), tools and transport equipment.

See also other related manuals / addendums:

- 4035 – Field Barrier.
- 4055 – Software Manual.
- 4058 – Approval Nameplates.

## 1.7 SYMBOLOGY USED

### 1.7.1 SIGNS OF WARNING

Be careful where the following symbols are shown. They indicate a potentially hazardous situation, and they warn that if the steps are not properly performed, they may cause serious injury, death or long-term risks to health of exposed persons.

		
General Danger	Crushing hazard	Power supply hazard

*Table 2*

Other symbols:



Indicates an **imminently hazardous** situation which, if not avoided, **will result** in death or serious injury (*High level of risk*).



Indicates a **potentially hazardous** situation which, if not avoided, **could result** in death or serious injury (*Medium level of risk*).



Indicates a **potentially hazardous** situation which, if not avoided, **could result** in minor or moderate injury (*Low level of risk*).



Indicates a **potentially harmful** situation which, if not avoided, **may result** in damage of the product itself or of adjacent objects (*Damage to property*).



## 1.7.2 SIGNS OF OBLIGATION

Be careful where the following symbols are shown. They indicate an obligation that must be respected.

 <p>General obligation</p>	 <p>Obligation to wear protective clothing.</p>	 <p>Obligation to wear protective footwear.</p>	 <p>Obligation to wear a helmet.</p>	 <p>Obligation to protect your eyes.</p>	 <p>Obligation to protect your hearing.</p>
---	--	--	---	---	--

*Table 3*

## 2 DEVICE DESCRIPTION

### 2.1 GENERAL DESCRIPTION

The Smart High-Performance (SHP) Positioner is a high capacity and high precision digital pneumatic positioner, mainly used as a valve care controller. Its flow rate and its control algorithm system and logic ensure excellent dynamic performance and very low stroking time. Its advanced diagnostics (on-line and off-line) have been specifically developed to meet all customer needs.

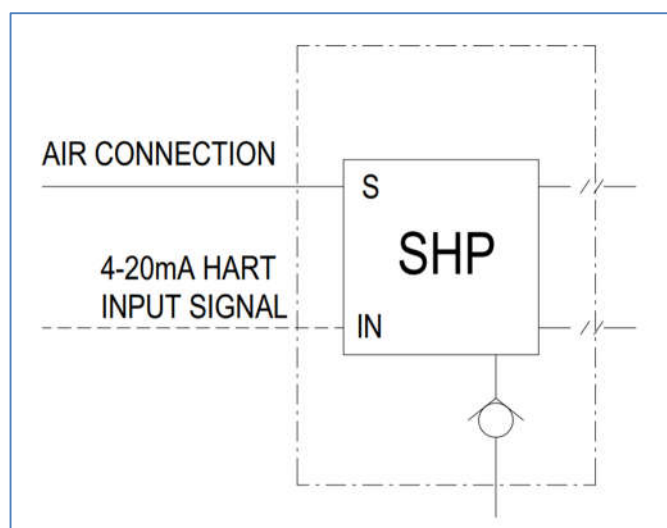

*Figure 1*

Positioners series SHP are designed to “pilot” and control the position of a valve on which they are mounted. They receive an analog input setpoint signal 4-20 mA, which is also an info about the required position of the valve. Then, it measures the position of the valve through an internal position sensor: the result is elaborated by the microprocessor, which activates a pilot valve, to modulate air or nitrogen (or, in specific condition, natural gas) sent to the chamber(s) connected to the actuator.

As an additional function, the SHP positioner may modulate a passive 4-20 mA analog feedback signal, to indicate the actual position of the valve.

SHP Positioner is designed to be installed in hazardous area within a mechanical / pneumatic control unit enclosure.

## 2.2 MODEL SELECTION

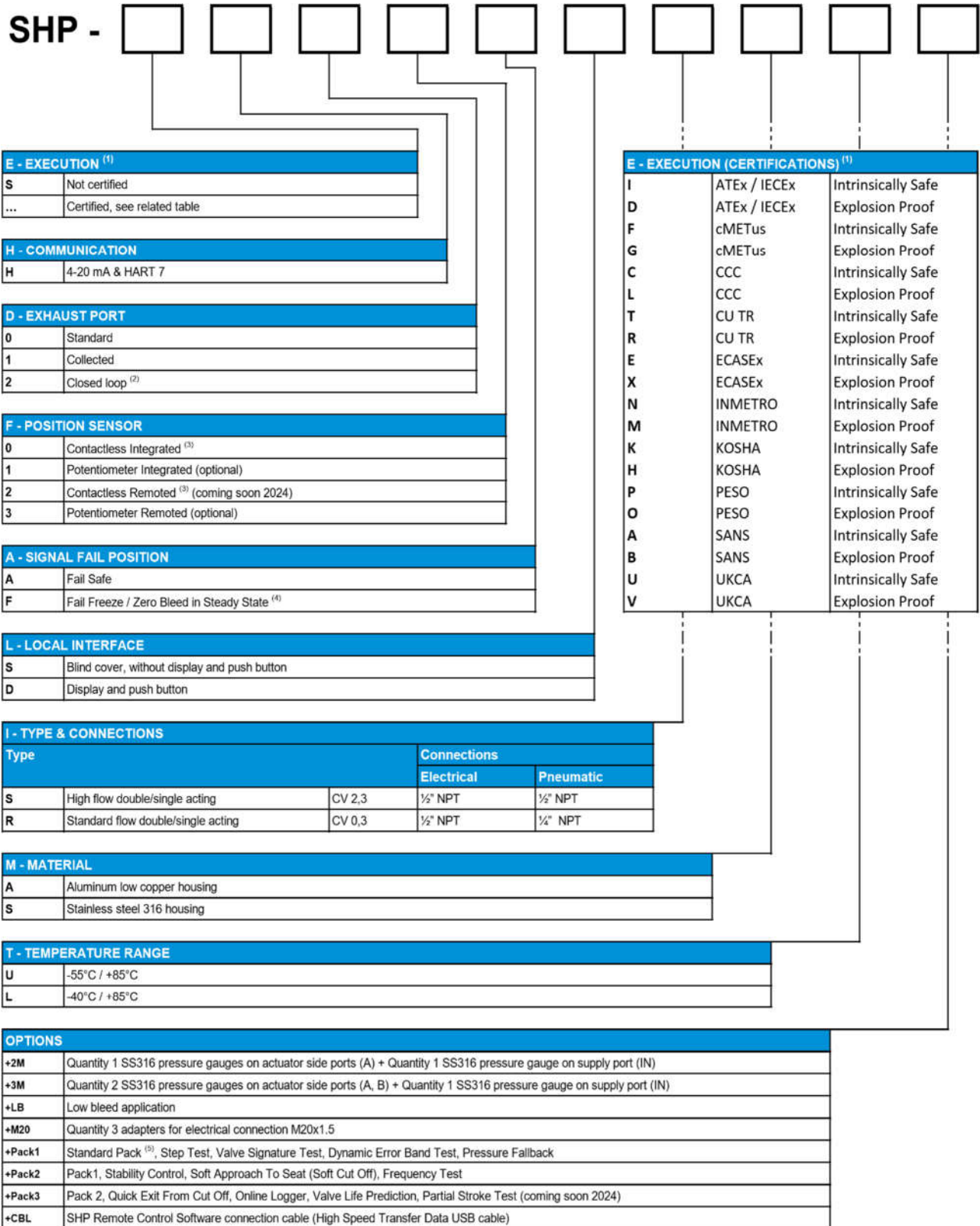

Table 4

- (1) All the configurations are IP 66 / NEMA 4X.
- (2) Available only for single acting actuators.
- (3) Additional magnet holders are required, depending on application. For further information, please see IOM.
- (4) Additional accessories are required. For further information, please see IOM.
- (5) Standard Pack included in the base model: Self-tuning, Pilot Test, System Status, Parameter Monitoring, Graph Comparison, Parameter Measurement, Events, Counters.



**Not all product configurations are available.**  
**For more information, please contact:**  
**[imisti.sales@imi-critical.com](mailto:imisti.sales@imi-critical.com)**  
**[sti.support@imi-critical.com](mailto:sti.support@imi-critical.com)**

### 3 TECHNICAL DATA

HARDWARE	DESCRIPTION
HOUSING	Stainless steel ASTM A351 / Low copper aluminium EN AC 43500
TOTAL WEIGHT	<9 kg (stainless steel version) / <4 kg (aluminium version)
TOTAL DIMENSIONS	Less than 190mm x 120mm x 145mm
MECHANICAL INTERFACE	Fixing screws according to VDE/ VDI 3845 (NAMUR)
PNEUMATIC CONNECTIONS	3 x ½" NPT female
ELECTRICAL CONNECTIONS	3 x ½" NPT female (Ex ia) / 1 x ½" NPT female (Ex d)
PNEUMATIC	DESCRIPTION
OPERATING PRESSURE RANGE	2.5 / 10.4bar – 150PSI (fail freeze 8bar, natural gas 6bar)
DESIGN PRESSURE	15bar / 220 PSI
INSTRUMENT GAS	Instrument air / natural gas / nitrogen / sweet and dry gases, according to ISO 8573-1 class 3 (oil concentration) and class 6 (dust concentration)
HIGH FLOW	Supply Cv max = 2.3 / Exhaust Cv max = 2.3 (180 Nm <sup>3</sup> /h @ 6bar / 21°C) (Ari consumption < 1.5 Nm <sup>3</sup> /h @ 6bar / 21°C)
LOW FLOW	Supply Cv ≤ 0.3 / Exhaust Cv = 0.3
POSITION FEEDBACK	DESCRIPTION
GENERAL NOTES	Contactless sensor into positioner, able to work 360° rotation
	Remote contactless sensor (option), up to 20m distance from the positioner
	Linear magnet kit (option) available when strokes up to 100mm / 4inch
ENVIRONMENT	DESCRIPTION
GENERAL NOTES	Operating temperature range = -55°C / +85°C, see Ex certificate for T4 - T5 - T6
	Storage temperature range = -55 / +85°C
	IP 66 / NEMA 4X
ELECTRONIC	DESCRIPTION
GENERAL NOTES	Communication protocol HART 7, 4-20mA
	Input voltage range = 10-30V (Ex ia) / 18-30V (Ex d) 17-30V (Ex ia fail freeze application)
	Impedance < 500Ω (Ex ia) / < 900Ω (Ex d) < 850Ω (Ex ia fail freeze application)
	Output signal 4-20mA passive loop (10±26.5V Ex ia / 14.5±24.5V Ex d)
	Digital input 24V isolated quantity 2 configurable

	Digital output 24V isolated quantity 2 configurable (quantity 2 NPN or quantity 1 NAMUR), external power supply needed
	Electric consumption < 1W
	Electronic internal loop update rate = 10ms
	Analog output update rate = 10ms
PERFORMANCES	DESCRIPTION
QUICK ACTION	100ms (time needed to achieve Cv max starting from Cv = 0)
HYSTERESIS + DEAD BAND	+/- 0.10% (measured at 21°C / 120° rotation)
REPEATABILITY	+/- 0.05% (measured at 21°C / 120° rotation)
SENSITIVITY	+/- 0.10% (measured at 21°C / 120° rotation)
LINEARITY	+/- 0.30% (measured at 21°C / 120° rotation)
THERMAL DRIFT	From -55°C to +85°C <0.4% (from -40°C to +85°C < 0.1%)
APPLICATIONS	DESCRIPTION
FAIL SAFE	Pneumatic connection A vent / B pressurized
FAIL FREEZE	With piezo valve and dedicated 3-way valve (N/A with Ex d certification)

*Table 5*



**Tubing with diameter greater than the product thread connection size are recommended as supply and exhaust tubing.**

EMC SUMMARY RESULTS – IMMUNITY			
PORT	PHENOMENON	BASIC STANDARD	PERFORMANCE CRITERIA
ENCLOSURE	Electrostatic discharge (ESD)	IEC 61000-4-2	A
	Radiated EM field	IEC 61000-4-3	A
	Rated power frequency magnetic field	IEC 61000-4-8	A
I/O SIGNAL/CONTROL	Burst	IEC 61000-4-4	B
	Surge	IEC 61000-4-5	B
	Conducted RF	IEC 61000-4-6	A

*Table 6*

## 4 CERTIFICATION

EXECUTION REFERENCE Ex ia / Ex d	CERTIFICATION	CERTIFICATE NUMBER
I/D	IECEX	IECEX EUT 23.0014X
I/D	ATEX	TBD
N/M	INMETRO	TBD
E/X	ECASEX	TBD
P/O	PESO	TBD
C/L	CCC	TBD
F/G	cMETus	TBD
T/R	CU TR	TBD
A/B	SANS	TBD
U/V	UKCA	TBD
K/H	KOSHA	TBD

Table 7

### 4.1 LABELS AND MARKING

A fixed label is attached on the product when the device is sold. It is forbidden to modify the information and the marks without previous written authorization by IMI STI.

For further information, contact IMI STI or see related manual.

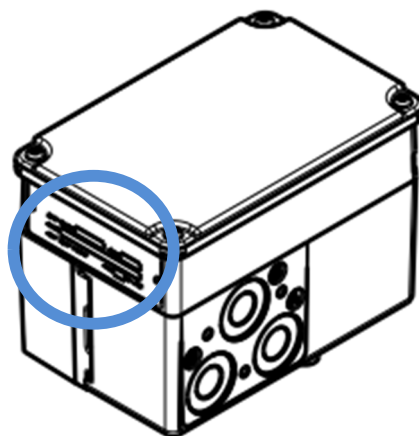

Figure 2

## 5 USER PROCEDURES



**Not performing the following procedures will invalidate the product warranty**

### 5.1 TRANSPORT



**Always wear protective clothing, gloves, and eyewear to prevent personal injury. Handling operations shall be made by qualified staff and in compliance with the laws and valid provisions.**

### 5.2 RECEPTION

Check if the model corresponds with the one reported on the purchase order and if no defects are visible on the product. Product related documents are furnished with documents accompanying the machinery where the product is mounted on. If the product is sold alone, contact IMI STI or download the documentation from IMI STI web site.

### 5.3 STORAGE

To maintain the product in perfect condition, proper attention must be observed to preserve the product during the storage period. Remember to:

- Place the product on a wood surface pallet or on metallic support, avoiding direct contact with the ground.
- Protect the product with appropriate covering.
- Make sure that plastic plugs are present on the pneumatic connections. If stored outdoor, replace plastic plugs with metal plugs that guarantee perfect tightness.
- Keep the product protected from weather conditions.



## 5.4 INSTALLATION



**Always wear protective clothing, gloves, and eyewear to prevent personal injury. Check with your process or safety engineer for any additional measures that must be taken to protect against process media.**

Remove the positioner from its packing, the pneumatic and electric port are protected by plastic plugs not suitable for working. They must be removed, and all ports not connected must be plugged with tight plug suitable for the pressure rating and area classification. Before installation take care about the following points:

- The pneumatic and electrical connections must be done according to the diagram and label.
- To achieve optimum performance from the SHP Positioner, use shielded cables.
- The use of a ground strap between the positioner housing and a suitable earthed point is necessary.
- When changing electrical connections inside the positioner housing, observe ESD handling precautions. The use of a conductive, earthed, wrist strap is recommended.
- The supply circuit must be protected to prevent the voltage or current exceeding the stated limits.
- The equipment must be provided with cable entries and filler plugs certified according to the required certification.
- The fluid must be chemically compatible with the gaskets and lubricant used in the installation.
- When positioner is installed in a hazardous area, ensure that electrical barriers are used between the positioner and the electrical power sources.
- Only trained personnel should permit to alter the software control parameters. Incorrect settings may lead to personnel injury and or property damage.

## 5.5 CHECKS TO BE PERFORMED BEFORE INSTALLATION

To allow a correct installation of the product, verify that the product outer surface is free from dust and dirt; if not, clean it and remove anything that might prevent a correct installation. Then, check if the coupling dimensions meet the specified ones and prepare all the necessary tools for the assembly and setting of the unit. With no power that the valve/actuator moves to the 0% signal position.

## 5.6 DIMENSIONAL DRAWING

For dimensional drawing, section and spare parts, see [chapter 6.0](#).

## 5.7 PNEUMATIC CONNECTIONS



**Check that the supply pressure is lower than the product design pressure. Use appropriate pipes and fittings (type, rating, material, and dimensions). The connection shall be made by qualified staff.**

To guarantee the best performances, follow the instructions below:

- Properly deburr the ends of rigid pipes.
- Properly clean the interior of pipes sending through them plenty of the supply fluid used in the system.
- Mould and fasten the connection pipes in order to avoid overstress on the connection parts and to avoid losing of the threaded connections.
- Use the recommended quantity of pipe sealant, only on male threads (no-hardening sealant is strongly recommended).
- Make the connections according to the machinery (i.e. actuator) pneumatic diagram.
- Check that no leakage occurs from pneumatic connections. If necessary, tighten the fittings.
- Collect tubing as indicated in the technical data table.

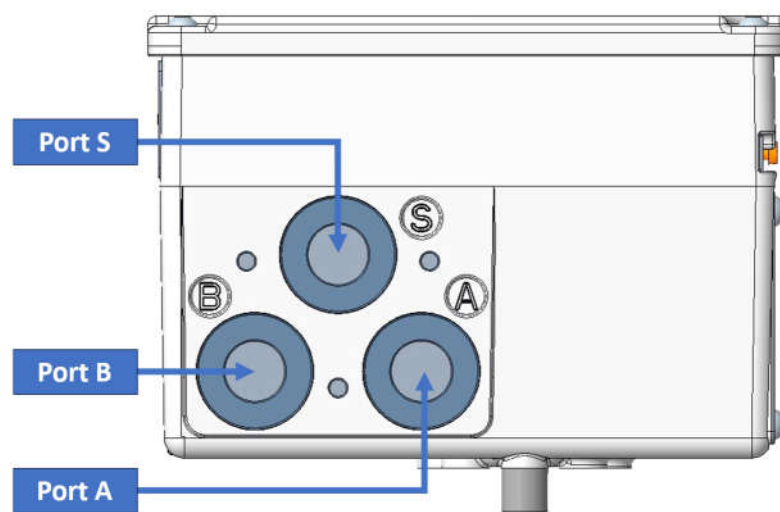

Figure 3

## NOTE

Pressure line port S, port A and port B are ½" NPT female.

To reach full flow performance, SHP positioner (High Flow version) requires that the piping between SHP and actuators has to be minimum ½" without any restriction, as short as possible. The pressure line pipe must be sized to avoid significant pressure drop during the actuator stroke.

During piping connection, be careful to keep clean the internal side of piping and fittings free from threaded sealing material and any other contaminant.

The SHP positioner can operate between 2.5 bar and 10.4 bar. Anyway, the line pressure must be set lower than actuator design pressure.

No load or bending moment are allowed by piping on SHP connection.

### 5.7.1 PNEUMATIC CONNECTIONS TO ACTUATOR

The SHP positioner is suitable for rotary or sliding actuators, double acting (with or without spring) or single acting. In case of power fail and/or signal fail, port "A" is fully exhausted and port B is fully pressurized.

#### 1) Double acting actuators

Port "A" must be connected to the actuator air chamber that has to be exhausted at signal fail.

Port "B" must be connected to the other actuator air chamber that has to be pressurized at signal fail.

#### 2) Single acting

Port "A" must be connected to the actuator air chamber.

Port "B" must be plugged.

To check the correct connections have been made, the system supply can be pressurized without any power signal. With no power, the valve/actuator moves to the 0% signal position.

### 5.8 ELECTRICAL CONNECTIONS

Electrical connection changes considering which SHP version is selected. Electrical connections depend on "Execution" version (intrinsically safe or explosion proof) and "Signal fail position version" (fail safe or fail freeze). Fail freeze version is available only for intrinsically safe execution.

### 5.8.1 INTRINSICALLY SAFE VERSION

The main electrical connections are:

- 4-20mA input signal.
- 4-20mA output signal.
- Digital input.
- Digital output.
- Position sensor remoted connection.
- Hart modem connection.
- High speed transfer data USB connection.

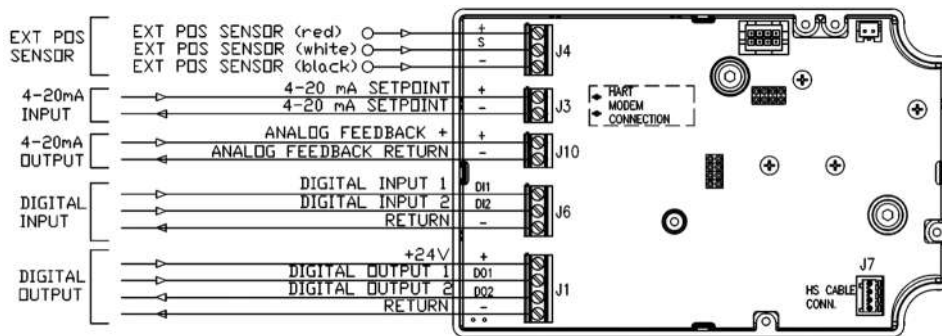

Figure 4

If a fail freeze version is selected, piezo valve must be wired by IMI STI (piezo valve and pneumatic commutators are required, as shown in the following circuit). This version is available only for intrinsically safe execution. Digital output is not available.

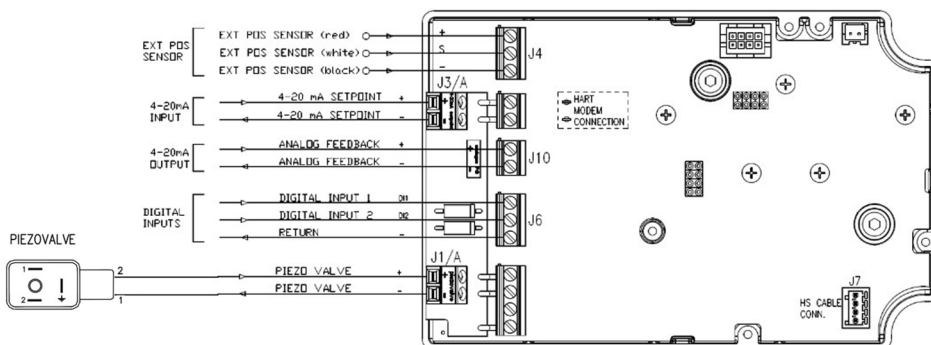

Figure 5

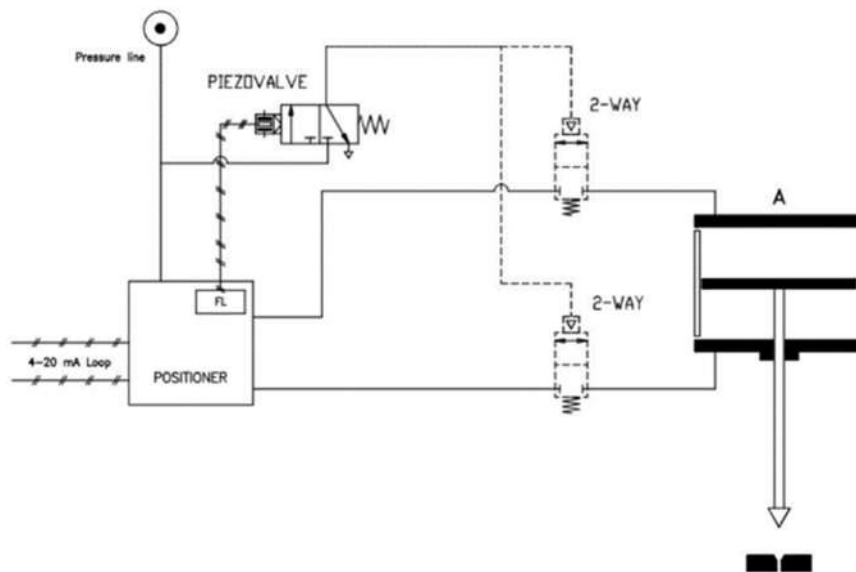

Figure 6

### 1) 4-20 mA input signal

Input port J3 should be connected to HART compliant 4-20 mA signal source. Input signal is used to:

- Provide power to the positioner.
- Inform the positioner about the 'Requested position'.



**Remember to properly select the intrinsically safe barrier, see positioner safety manual and positioner certificate.**

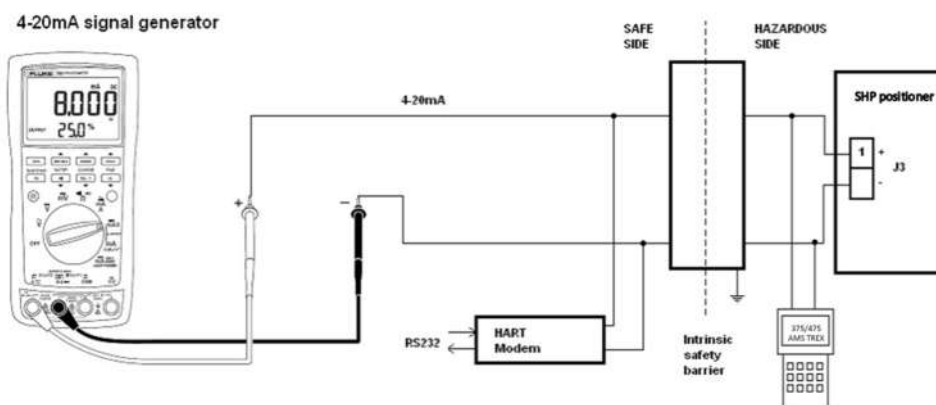

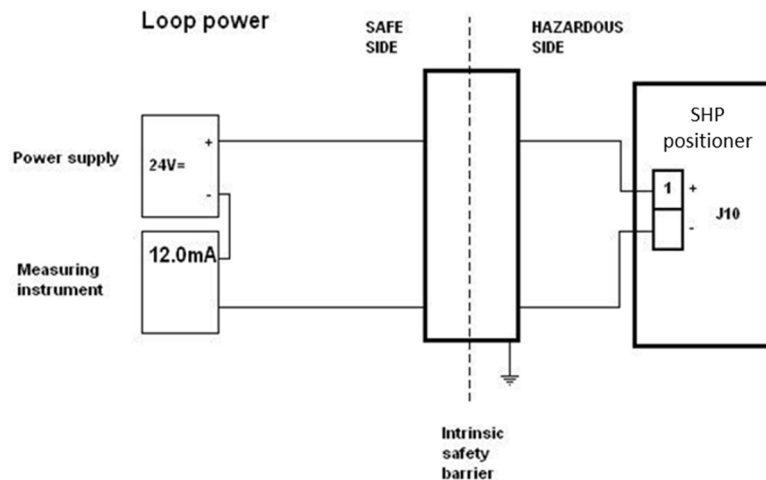

Figure 7

## 2) 4-20 mA output signal

Output port J10 should be connected to 24V power source. Output signal is used to inform customer about the “Actual position”.

	<p><b>Remember to proper select the intrinsically safe barrier, see positioner safety manual and positioner certificate.</b></p>
---	--



*Figure 8*

## 3) Digital input

Digital Input is isolated by an optocoupler. The input resistance value is 2200 ohms. Apply a 24Vdc signal between the digital input and the return signal to energize the input.

## 4) Digital output (not available for fail freeze applications)

Digital output is isolated by an optocoupler. The output is made by a transistor with a series resistor of 1Kohm. When the output is energized the impedance is less than 4 Kohm, when de-energized the impedance is greater than 100 Kohm. The optocoupler requires an external power source to be energized via J1 pins 1 & 4.

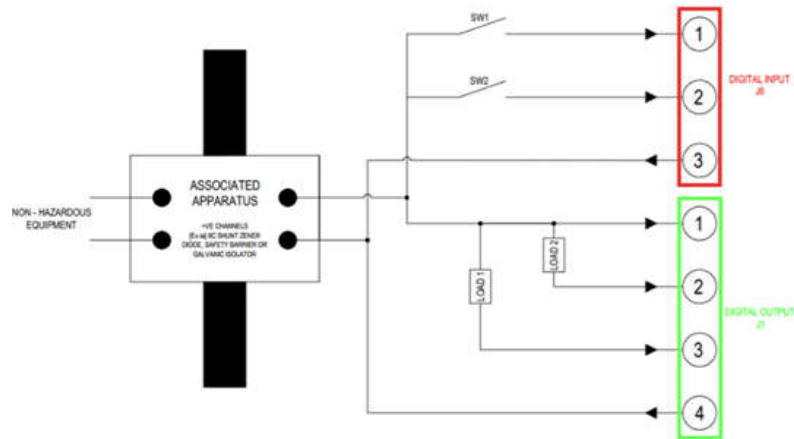

Figure 9

### 5) Position sensor remoted connection

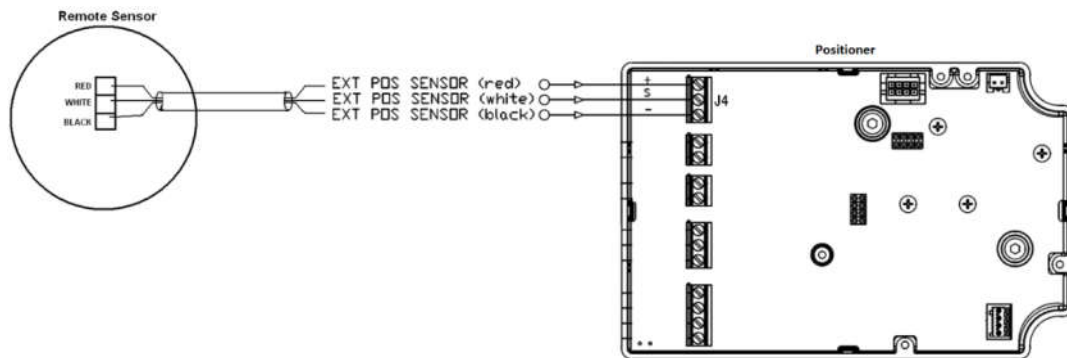

Figure 10

Shield connection can be different based on electrical noise and earth ground quality:  
 Basic solution: connect the cable shield only at J4/3 (together with black cable).  
 Second solution: connect the shield only at positioner earth connection (see related chapter).

### 6) High speed transfer data USB connection

Suitable for maintenance and commissioning. A dedicated interface cable is needed.

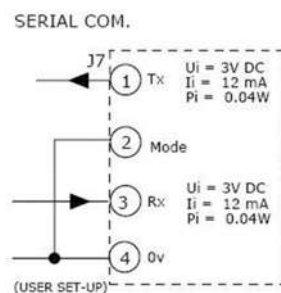

Figure 11

## 5.8.2 EXPLOSION PROOF VERSION



With explosion proof version, the following connections are not available:

- Digital input
- Digital output

Explosion proof is not available with fail freeze applications.

The main electrical connections are:

- 4-20mA input signal (using positioner Ex d barrier).
- 4-20mA output signal (using positioner Ex d barrier).
- Position sensor remoted connection (same as intrinsically safe version).
- Hart modem connection (same as intrinsically safe version).
- High speed transfer data USB connection (same as intrinsically safe version).

### 1) 4-20 mA input / output signal

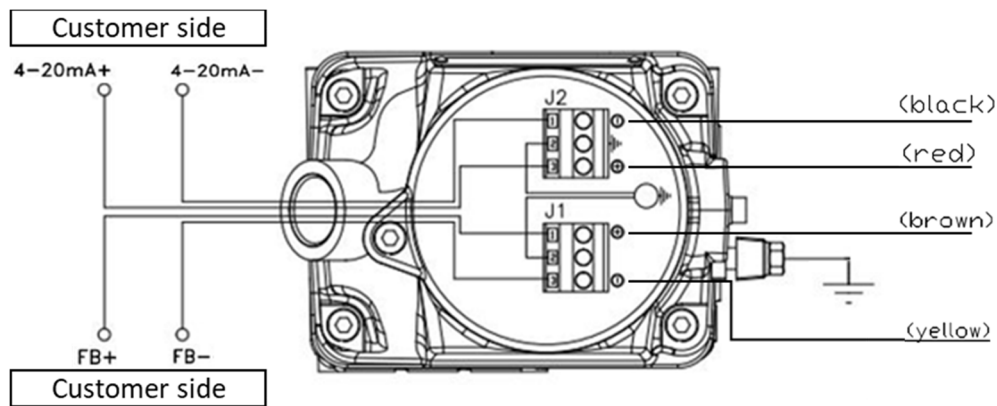

Figure 12 – Ex d barrier

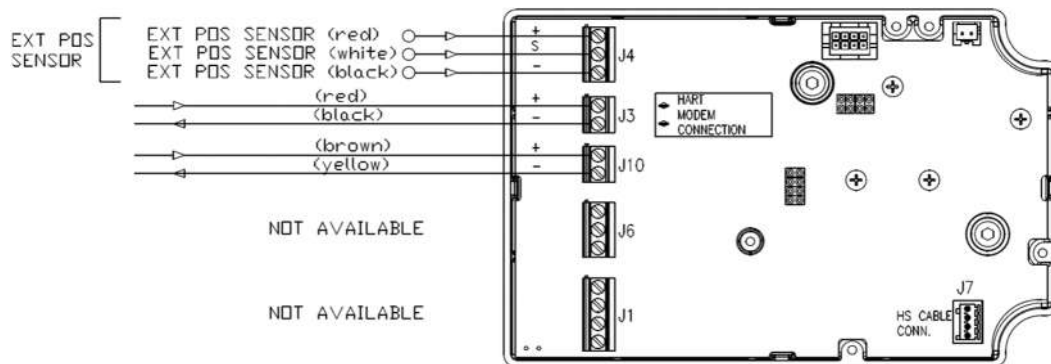

Figure 13



Remember to proper connect the Ex d barrier earthing port, see related manual





See below to understand how to manage input impedance in case your DCS has limited voltage output.

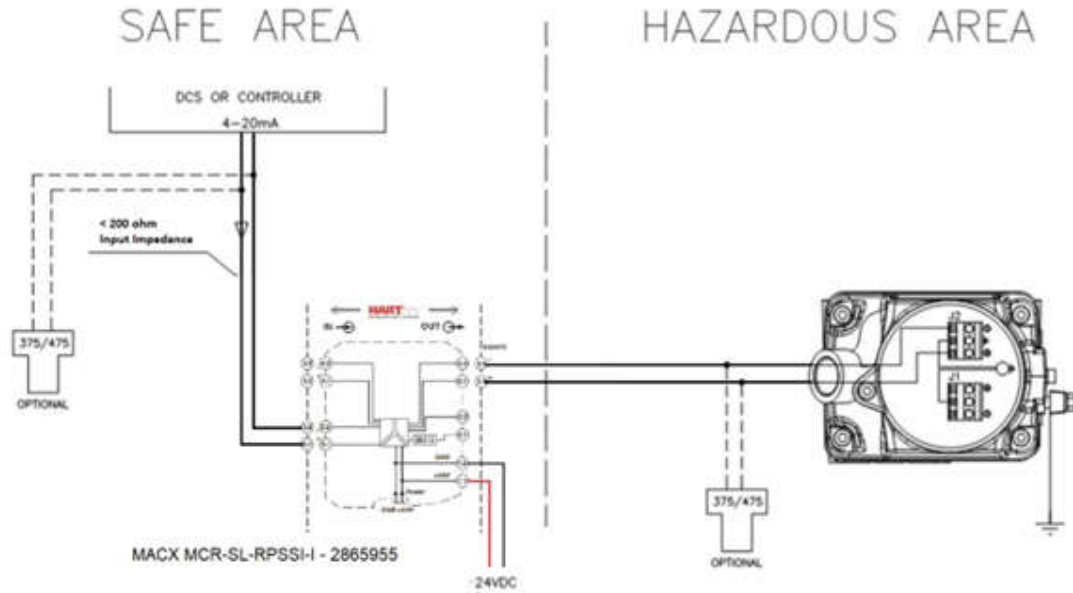

Figure 14 – Option 1

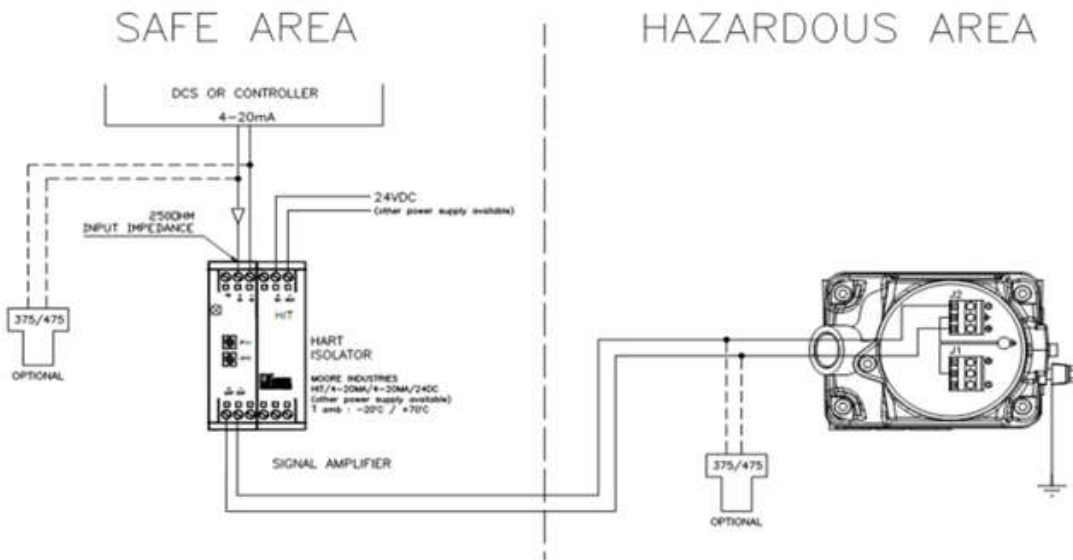

Figure 15 – Option 2

## 5.9 EARTHING CONNECTIONS

The earthing connection is guaranteed through the product fixing screws on main enclosure. If, for any reason, no earthing connection is guaranteed, ensure it connecting the product to earth.

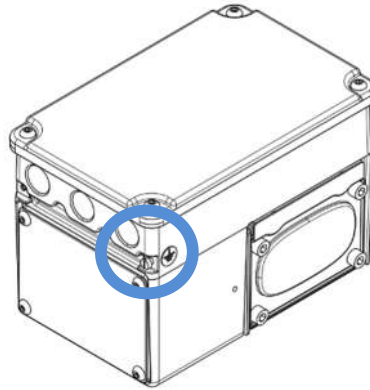

Figure 16

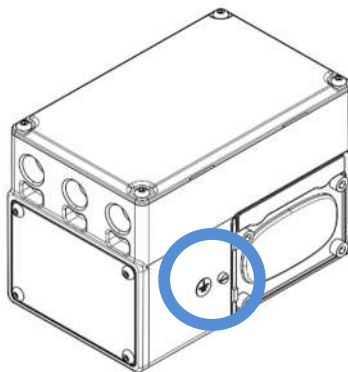

Figure 17

## 5.10 DISASSEMBLING



**Before starting any disassembly operations, it is mandatory to disconnect the electric power/signal and discharge air. Be sure that no pressurized fluid could be present inside the product, fittings, tubing.  
The staff must be qualified for the required operation.**

## 6 OPERATION AND USE



It is severely forbidden to use the product for purpose or application other than those for which it was designed and here above specified.  
The product contains fluid under pressure. Pay attention using it.

### 6.1 OPERATION DESCRIPTION

Use the positioner considering technical data and all the information reported in this manual.

### 6.2 PRODUCT DESCRIPTION

In the following paragraphs, you will find information regarding dimensions, mechanical interfaces, pneumatic and electrical connections, related to the main models available.

#### 6.2.1 SHP-Ix00xxxAx (I = INTRINSICALLY SAFE, A = ALLUMINIUM VERSION)

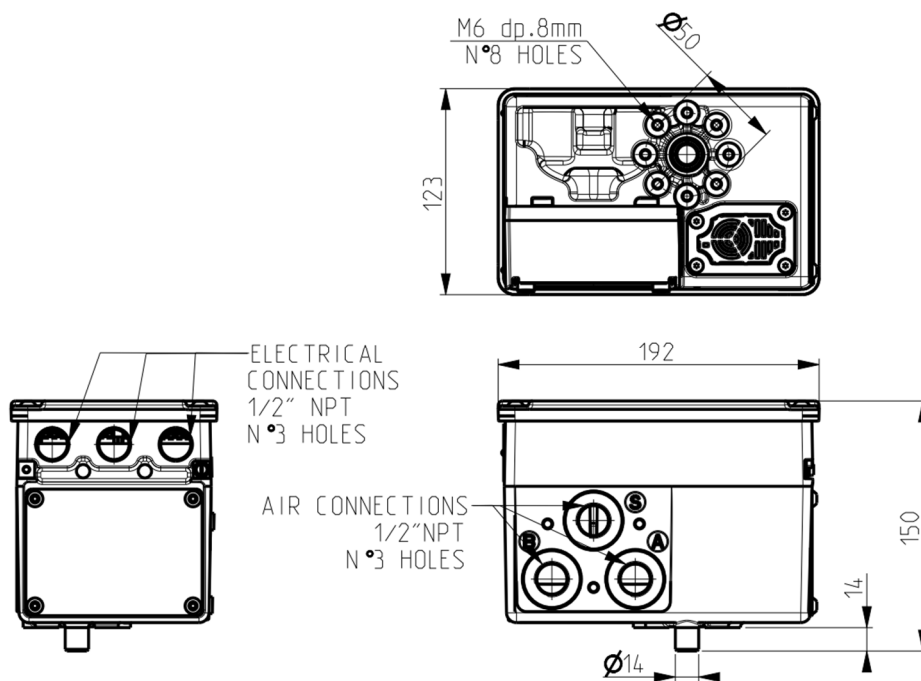

Figure 18

### 6.2.2 SHP-Ix00xxxSx (I = INTRINSICALLY SAFE, S = STAINLESS STEEL VERSION)

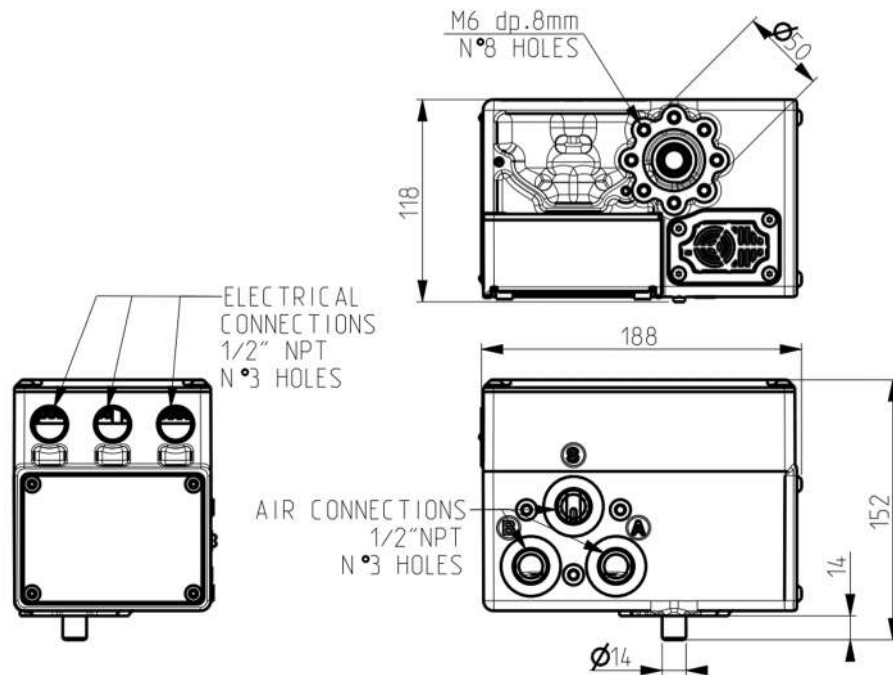

Figure 19

### 6.2.3 SHP-Dx00xxxAx (D = EXPLOSION PROOF, A = ALLUMINIUM VERSION)

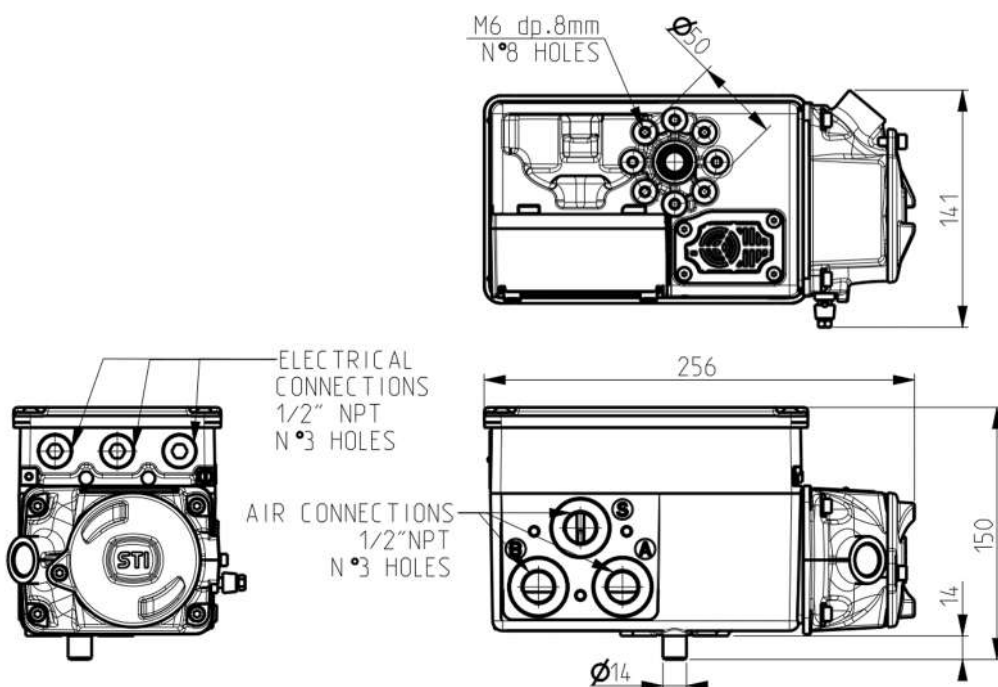

Figure 20

### 6.2.4 SHP-Dx00xxxSx (D = EXPLOSION PROOF, S = STAINLESS STEEL VERSION)

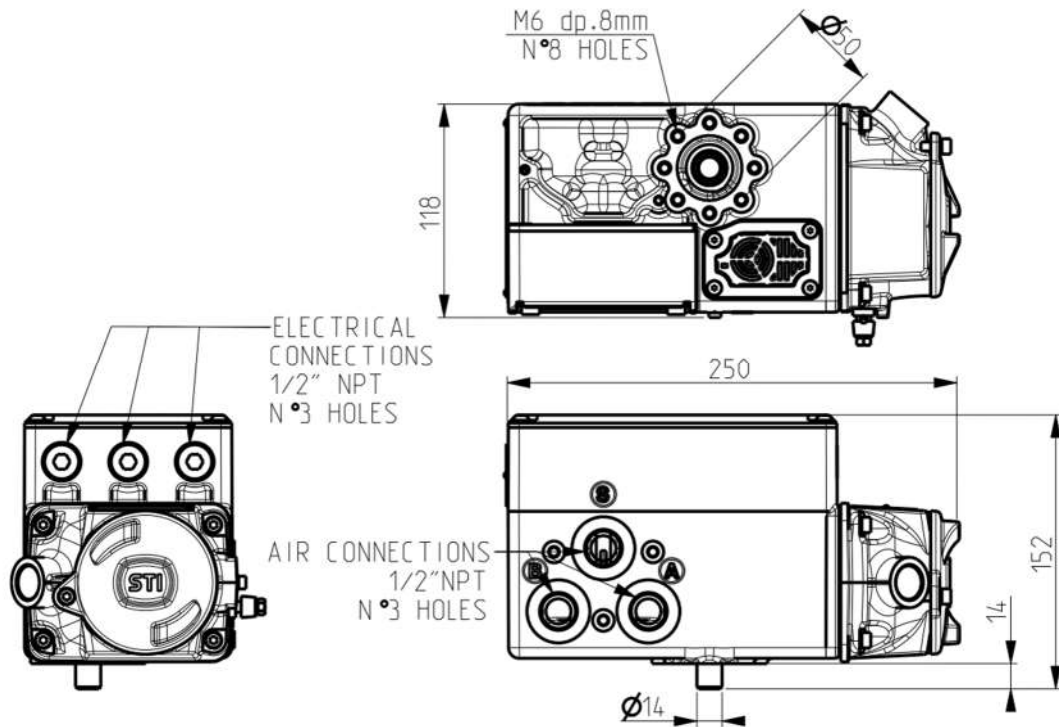

Figure 21

### 6.2.5 CONTACTLESS REMOTED (ALLUMINIUM VERSION)

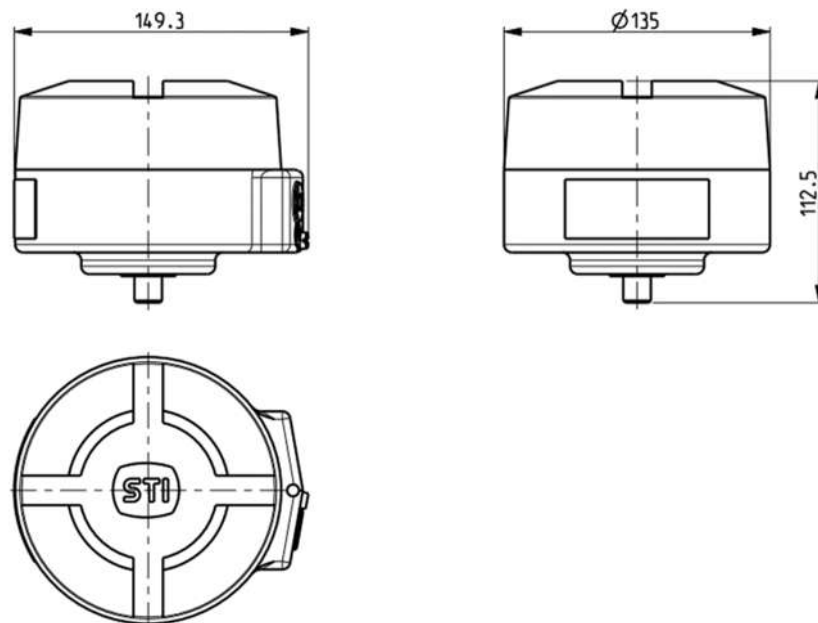

Figure 22

### 6.2.6 CONTACTLESS REMOTED (STAINLESS STEEL VERSION)

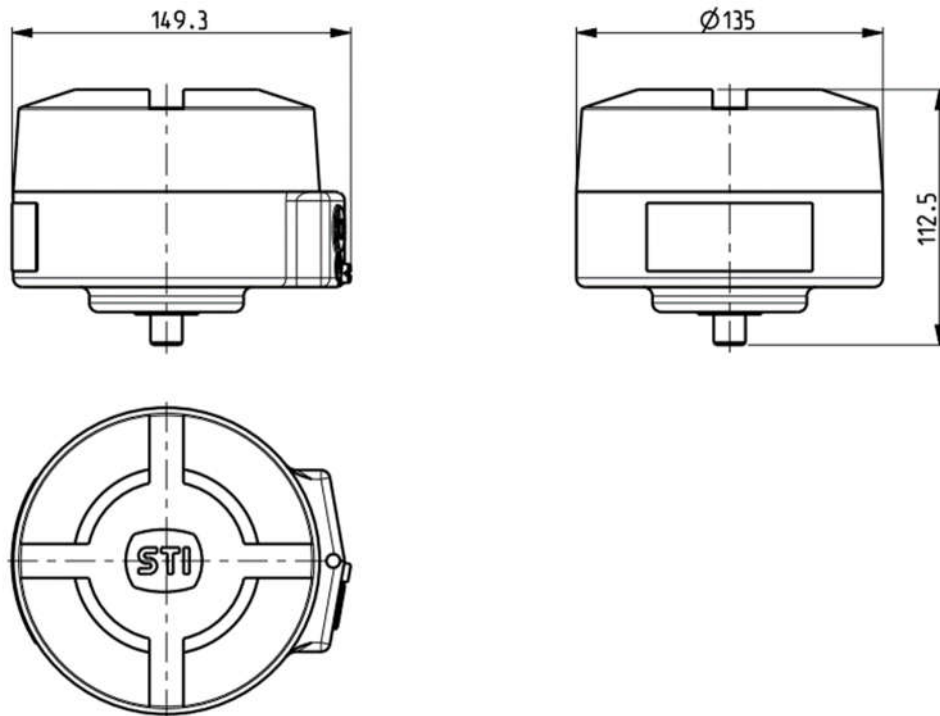

Figure 23

### 6.3 INTENDED USE

This product is an electro-pneumatic positioner for pneumatic actuators.

IMI STI will not be liable for any possible damage or physical injury resulting from use in other than the designated applications or by lack of care during installation, operation, adjustment, or maintenance. Such risks lie entirely with the user.

Considering that IMI STI has no direct control over applications, operation or maintenance conditions, it is the operator's responsibility to comply with all applicable safety rules: it is the sole responsibility of the operator to ensure that the local health and safety regulations are adhered to.

Depending on the specific working conditions, additional precautions may be requested.

Please inform IMI STI if you face unsafe situations not described in this Instruction Manual.

### 6.4 REASONABLY FORSEEABLE MISUSE

A short list of reasonably foreseeable misuse:

- Installation in ambient with not planned conditions (i.e. climatic conditions different from the specified conditions).
- Incorrect fluid used inside the product.
- Supply pressure greater than maximum operating pressure.
- Input voltage greater than maximum allowable value.

### 6.5 OPERATING LIMITS

The product label and/or this manual (see technical data) indicate the main operating conditions of this product.

## 6.6 RESIDUAL RISKS

A short list of possible risks:

- Risk due to movements of loads during mounting phase.
- Crushing during assemblage servicing.
- Extreme high or low surface temperature, as consequence of ambient temperature, must be considered a risk of person injury in case of contact.
- Hazardous fluid emission (i.e. when natural gas is used as fluid under pressure).

## 7 INSTRUCTION FOR THE OPERATOR

During the start-up of the product, proceed as follows:

- Check that the pressure and quality of the air supply (filtering degree, dehydration) are as prescribed.
- Check that there are not leaks in the pneumatic connections. If necessary, tighten the fittings.
- Set the product according to the schematic diagram.

### 7.1 ELETTROMAGNETIC INTERFERENCE

During the start-up of the product, proceed as follows:

- Do not lay signal lines close to power lines. Power lines produce interference in their near vicinity, which may affect measured value transmission on the signal line.
- When changing electrical connections inside the positioner housing, observe ESD handling precautions. The use of a conductive, earthed, wrist strap is recommended.
- It is recommended that lid is rest closed in normal operation.



**Always observe the specifications and special requirements for your positioner stipulated in the applicable certificate.**

### 7.2 PNEUMATIC SAFETY

During the start-up of the product, proceed as follows:

- Observe the accident prevention rules of the H&S organizations.
- Observe the safety instructions for the pneumatic actuator used.
- Before connecting the air pipes blow them out to remove dust, splinters, and other particles.



**Take suitable precautions to ensure that even in case of malfunctions the positioner's maximum admissible operating pressure is not exceeded. Otherwise, positioner and/or actuator may be damaged.**



### 7.3 ELECTRICAL SAFETY

During the start-up of the product, proceed as follows:

- Observe the accident prevention rules of the H&S organizations.
- Observe the safety instructions for the pneumatic actuator used.
- Observe the standards and safety regulations for the installation and operation of electrical systems.
- Observe all electrical specifications in these operating instructions or in the drawing.



**For electrical installation of explosion-protected devices, observe all standards, regulations and directives governing explosion protection and applicable for the construction and use of explosion-protected systems, the directives for explosion protection and the special requirements and specifications for your devices.**

**Make sure that:**

- **Used in situations that comply with the certification conditions stated in this handbook.**
- **Maintained only by qualified personnel with adequate training on hazardous area instrumentation.**
- **This product is not intended for use in life support systems.**
- **The use of a ground strap between the positioner housing and a suitable earthed point is necessary.**
- **The supply circuit must be protected to prevent current exceeding the fixed limit.**
- **The equipment must be provided with cable entries and filler plugs certified according to the required certification.**

## 8 MAINTENANCE

### 8.1 PERIODIC INSPECTIONS



Take care that a build-up of dust or dirt on the product can inhibit cooling and contribute to increase surface temperature. The user should plan and provide for a periodic cleaning and maintenance program that will maintain the external surface of the positioner free from excessive layer of dust.

Operation and maintenance shall be carried out by skilled staff.

Product disassembling and reassembling shall be carried out only by IMI STI authorized operators.

### 8.2 SPECIAL MAINTENANCE

The product does not need special maintenance considering standard applications; if special maintenance is required, send back the device to IMI STI.

Product disassembling and reassembling shall be carried out only by IMI STI authorized operators.

Always avoid unpredictable movement of the actuator: before making changes to the positioner, make sure that the supply pressure and electrical power is isolated from the positioner.

### 8.3 REPAIRS

When needed, send back the device to IMI STI for any repairing.

Product disassembling and reassembling shall be carried out only by IMI STI authorized operators.

## 9 TROUBLESHOOTING

Event	Possible cause	Remedy
Do not work properly	Low supply pressure	Adjust supply pressure
	Cables not connected correctly	Check electric cables
	Defective internal component (enclosure, springs, spool, etc...)	Call IMI STI S.r.l.
Leakages on pneumatic circuits	Deterioration and/or damage to gasket and/or loosed fittings	Call IMI STI S.r.l.
	Damage of fittings	Change pneumatic fittings

## 10 DECOMMISSIONING

Subject	Hazardous	Recyclable	Disposal
Metals	No	Yes	Use licensed recyclers
Plastics	No	Yes	Use licensed recyclers
Rubbers	Yes	No	May require special treatment before disposal, use specialist waste disposal companies
Greases	Yes	No	May require special treatment before disposal, use specialist waste disposal companies
Electronic boards	Yes	No	May require special treatment before disposal, use specialist waste disposal companies
Electric cables	No	Yes	Use licensed recyclers



**Before starting any disassembly operations, it is mandatory to disconnect the pneumatic and electric power, and exhaust the pressure inside the positioner.**



**The product decommissioning shall be made by specialized operators. Check local authority regulation before disposal**

**IMI STI - Headquarters**

Via Dei Caravaggi 15  
24040 Levate (BG)  
Italy

Tel. +39 035 2928.2  
Fax +39 035 2928.247

**IMI Critical Engineering**

Lakeside, Solihull Parkway  
Birmingham Business Park  
Birmingham B37 7XZ  
United Kingdom

Tel. +44 (0)121 717 3700  
Fax +44 (0)121 717 3701

[www.stiactuation.com](http://www.stiactuation.com)  
[www.imi-critical.com](http://www.imi-critical.com)  
[imisti.sales@imi-critical.com](mailto:imisti.sales@imi-critical.com)