

SC/V - VALVE ACTUATOR SPRING RETURN INSTRUCTION MANUAL 5018





*Engineering
GREAT Solutions*

STI S.r.l. has taken every care in collecting and verifying the documentation contained in this Instruction Manual. The information herein contained are reserved property of STI S.r.l.

INDEX

1	GENERAL INFORMATION	1
1.1	GENERALITIES	1
1.2	MANUFACTURER.....	1
1.3	TERMS AND CONDITIONS	1
1.4	MANUFACTURER’S LIABILITY	1
1.5	APPLICABLE STANDARDS AND DIRECTIVES	2
1.6	SYMBOLGY USED.....	2
2	DEVICE DESCRIPTION	3
3	TECHNICAL DATA.....	4
4	LABEL.....	5
5	OPERATING CONDITIONS AND INTENDED USE.....	6
5.1	OPERATING CONDITIONS.....	6
5.2	INTENDED USE.....	6
6	TRANSPORT	7
7	RECEPTION.....	7
8	STORAGE.....	7
9	INSTALLATION	8
9.1	CHECKS TO BE PERFORMED BEFORE INSTALLATION	8
9.2	ALIGNMENT OF THE SC/V VALVE ACTUATOR.....	8
9.3	PNEUMATIC CONNECTIONS.....	9
9.4	EARTHING CONNECTION.....	9
10	INSTRUCTION FOR THE OPERATORS	10
10.1	FIELD ACTIVITIES	10
10.2	RESIDUAL RISKS	10
11	MAINTENANCE	11
11.1	PERIODIC INSPECTIONS AND MAINTENANCE.....	11
11.2	EXTRAORDINARY MAINTENANCE	11
11.3	GREASES.....	12
12	PARTS LIST GENERAL ASSEMBLY	13
12.1	STEM EXTENDED + CASTING ACTUATOR.....	13
12.2	STEM EXTENDED + NO CASTING ACTUATOR.....	17
12.3	STEM RETRACTED + CASTING ACTUATOR.....	23
12.4	STEM RETRACTED + NO CASTING ACTUATOR.....	27
13	TROUBLESHOOTING	32
14	SPARE PARTS	32
15	DISASSEMBLING.....	33
16	DECOMMISSIONING.....	33
	ANNEX A_SC/V200-320: STEM EXT. + CASTING CYL.....	A1
	ANNEX B_SC/V200-320: STEM RETR. + CASTING CYL.....	B1
	ANNEX C_SC/V200-320 RV: STEM RETR. + CASTING CYL.....	C1
	ANNEX D_SC/V300-400-500-520: STEM EXT. + NO CASTING CYL.....	D1
	ANNEX E_SC/V300-400-500-520: STEM RETR. + NO CASTING CYL.....	E1

1 GENERAL INFORMATION

Important	 <p>This Instruction Manual is an integral part of the machine, it should be carefully read before carrying out any operation and it should be kept for future references. The operators shall adopt the safety precautions required by the country where the product is installed.</p> <p>This Instruction Manual is realized in accordance with the Directive 2006/42/CE.</p>
------------------	--

1.1 Generalities

STI S.r.l. actuators are conceived, manufactured and controlled according to the Quality management System in compliance with EN ISO 9001 International Standard.

1.2 Manufacturer

With respect to Machinery Directive 2006/42/EC, the Manufacturer of the described SC/V valve actuator is STI S.r.l. as specified on the label.

STI S.r.l. Via Dei Caravaggi 15
24040 Levate (BG) Italy
Tel. +39 035 2928.2
Fax +39 035 2928.247
imisti.sales@imi-critical.com

1.3 Terms and conditions

STI S.r.l. guarantees each single product to be free from defects and to conform to current goods specifications. The warranty period is two years from the date of shipment to the first user. The warranty does not cover special products or components not covered by warranty in their turn by subcontractors. No warranty is given for products which have been subject to improper storage, improper installation, improper maintenance or which have been modified or repaired by unauthorised personnel.

1.4 Manufacturer's liability

The SC/V valve actuator is designed in accordance with the applicable International Rules and Specifications, but the following regulations must be observed in any case:

- the general and safety regulations;
- the plant specific regulations and requirements;
- the proper use of personal devices, protective devices (glasses, clothing, gloves, etc), tools and transport equipment.

STI S.r.l. declines all liability in the event of:

- use SC/V valve actuator in other applications than the designated ones;
- use of the SC/V valve actuator in contravention of local safety at work legislation;
- lack of care during transport, installation, operations, maintenances of the SC/V valve actuator or incorrect application of the instructions provided on the SC/V valve actuator label and in this manual;
- modifications or repairs without STI S.r.l. authorisation;
- work done on the unit by unqualified or unsuitable operators.

Considering that STI S.r.l. has no direct control over particular applications, operation or maintenance conditions, it is the operator's responsibility to comply with all applicable safety rules; it is the sole responsibility of the operator to ensure that the local health and safety regulations are adhered to. Depending on the specific working conditions, additional precautions may be requested. Please inform STI S.r.l. urgently if you face unsafe situations not described in this Instruction Manual.

1.5 Applicable Standards and Directives

EN ISO 12100:2010	Safety of machinery - General principles for design - Risk assessment and risk reduction
IEC 61508:2010	Functional safety of electrical / electronic / programmable electronic safety-related systems
2006/42/EC	Machinery Directive
97/23/EC	Pressure Equipments Directive (PED)
94/9/CE	Equipments used in potentially explosive atmospheres (ATEX)

1.6 Symbology used

Dangerous symbols: be careful where these symbols are shown, they indicate a potentially hazardous situation and they warn that if the steps are not properly performed, may result causing serious injury, death or long-term risks to the health of exposed persons.



GENERAL DANGER



DANGER POWER SUPPLY



CRUSHING HAZARD

Obligation symbols: if these symbols are shown, the corresponding direction shall be followed.



General obligation
(with the possible
supplementary
signboard)



Must wear
protective
clothing.



Must wear
protective
footwear.



Must wear
protective
helmet.



Must wear
protective
glasses



Must wear
earplugs

2 DEVICE DESCRIPTION

The SC/V valve actuator is made by four main parts:

- the cylinder group, with a piston inside that divides the internal volume in two chambers. A first stem (actuator stem) connects the piston to the valve stem. Another stem connects the piston to the spring/springs;
- the spring group, collocated on the top of the cylinder;
- the yoke, that fix the cylinder to the valve;
- the manual override (not always required).

Different kind of pneumatic accessories could be mounting on the SC/V valve actuator depending on the performance required.

There are four type of SC/V valve actuator Spring Return:

- Single Acting Stem Extended, where the spring extend the actuator stem;
- Single Acting Stem Retracted, where the spring retract the actuator stem;
- Double Acting Stem Extended, where the spring extend the actuator stem;
- Double Acting Stem Retracted, where the spring retract the actuator stem.



Figure 1 – SC/V valve actuator

3 TECHNICAL DATA

Model	Double/Single Acting Stem Extended (****)	
	Casting Cylinder	No Casting Cylinder
Cylinder material	Aluminum	Carbon steel, Stainless steel, Fiber
Size (cylinder diameter) / Stroke (*)	150mm/≤40mm 200mm/≤150mm 250mm/≤150mm 320mm/≤300mm	200mm, 260mm, 300mm, 330mm, 390mm, 400mm, 420mm, 500mm, 520mm, 600mm, 635mm, 650mm, 735mm, 835mm, 850mm
Standard design pressure (**)	10bar (****)	10bar (****)
Standard operating temperature range (***)	-20°C/+70°C	-20°C/+70°C
Expected lifetime	20 years	20 years

Model	Double/Single Acting Stem Retracted (****)	
	Casting Cylinder	No Casting Cylinder
Cylinder material	Aluminum	Carbon steel, Stainless steel, Fiber
Size (cylinder diameter) / Stroke (*)	150mm/≤40mm 200mm/≤153mm 250mm/≤153mm 320mm/≤305mm	200mm, 260mm, 300mm, 330mm, 390mm, 400mm, 420mm, 500mm, 520mm, 600mm, 635mm, 650mm, 735mm, 835mm, 850mm
Standard design pressure (**)	10bar (****)	10bar (****)
Standard operating temperature range (***)	-20°C/+70°C	-20°C/+70°C
Expected lifetime	20 years	20 years

(*) Stroke for No Casting Actuators not defined in this table.

(**) For some special application the design pressure is 12 bar.

(***) For some special application the operating temperature range could be another one included in the extended temperature range from -60°C to 100°C.

(****) Double and single acting actuators have the same design with the difference that in the first case both the cylinder chambers are connected to the pneumatic supply line.

(*****) For double acting actuators: $\text{Air_Thrust [N]} + \text{Spring_Thrust [N]} \leq 0.1 * 10 [\text{bar}] * \text{Size}^2 [\text{mm}^2] * \pi / 4$.

4 LABEL

Every SC/V valve actuator is provided with a label contains the main operating conditions and serial number. The label may change if the SC/V valve actuator is sold with reference to a Certificate of product and/or system issued by Notified Body Exterior or Certificate of Conformity issued by STI S.r.l..





 STI s.r.l. Via Dei Caravaggi 15 24040 LEVATE(Bg)-ITALY www.imi-critical.com - FAX +39 035 2928247					
MODELLO Model	<input type="text"/>	MATRICOLA Ident. No	<input type="text"/>		
DN Size	<input type="text"/> mm	CORSA Stroke	<input type="text"/> mm	ALIM.MAX Supply	<input type="text"/> bar
SEGNALE Signal	3 ÷ 15 psi <input type="checkbox"/>	0.2 ÷ 1 bar <input type="checkbox"/>	4 ÷ 20mA <input type="checkbox"/>		
CAMPO SPECIALE Special range	<input type="text"/>	AZIONE Action	D. <input type="checkbox"/>	R. <input type="checkbox"/>	ON/OFF <input type="checkbox"/>
SIGLA Tag.No	<input type="text"/>				

Figure 2 – SC/V standard label

Warning 	<p>It is severely forbidden to use the SC/V valve actuator under conditions other than those provided on the label.</p>
---	--

Important 	<p>It is forbidden to modify the information and the marks without previous written authorization by STI S.r.l..</p> <p>Do not remove the label and/or replace with other label.</p>
---	--

5 OPERATING CONDITIONS AND INTENDED USE

<p>Warning</p> 	<p>It is severely forbidden to use the SC/V valve actuator for purpose or application other than those for which it was designed and here specified.</p>
---	--

5.1 Operating conditions

The label fastened on the SC/V valve actuator contains the main operating conditions for the specified application (see Section 4). Other operating conditions are reported on the documents accompanying the actuator. For general operating conditions see Section 3.

5.2 Intended use

The SC/V valve actuator series has been specifically designed for control valves, typically used in on-off application or regulation mode. In order to open/close the valve without the support of the supply fluid, in some application the manual override is required. Every manual override is provided with a label contains the correct using steps.



STI s.r.l. Via Dei Caravaggi 15 24040 LEVATE(Bg)-ITALY
www.imi-critical.com - FAX +39 035 2928247

CONNECTION OF THE HANDWHEEL CONTROL
Inserimento comando manuale

1) Turn the handwheel clockwise to the stop ring splined to the cylinder shaft
Girare il volantino in senso orario fino a raggiungere l'anello di fermo calettato sullo stelo del cilindro

2) Insert the pin in the hole
Inserire la spina nell'apposito foro

3) Open the by pass valve
Aprire la valvola di by-pass

4) Do not force the handwheel beyond the limits of the stroke
Non forzare il comando manuale oltre i limiti di fine corsa

Figure 3 – Manual override standard label

After the manual override using, take off the manual override pin and then check the correct behavior of the SC/V valve actuator with a functional test or a visual check of the pin.

6 TRANSPORT

Warning 	<p>The following instructions must be respected:</p> <ul style="list-style-type: none"> - operations must be carried out only by skilled operators; - always wear protective clothing, gloves, and eyewear to prevent personal injury. Check with your process or safety engineer for any additional measures that must be taken to protect against process media.
---	--

Important 	<p>The lifting and handling should be made in compliance with the laws and provisions in force.</p>
---	---

Lift the SC/V valve actuator with belts, using its eyebolts. Make sure that the belts never scratches the accessories and pneumatic/electric connection.

7 RECEPTION

SC/V valve actuator leave the factory in perfect condition. Performances of each unit are guaranteed by tests and data reported on a specific Test Report. At the reception of the SC/V valve actuator:

- check that the model corresponds with that of order confirmation;
- check that the pneumatic diagrams, wiring diagrams and dimensional drawing are furnished with document accompanying the actuator;
- check that the SC/V valve actuator was not damaged during transportation. If necessary renovate the painting according to the specification reported on the order confirmation.

8 STORAGE

In order to maintain the guaranteed actuator performances until the SC/V valve actuator is installed on site, proper attention must be observed for preservation during the storage period. If the SC/V valve actuator needs storage before installation:

- place it in a dry, clean place and take all necessary measures to avoid contact with dust, dirt and humidity during storage;
- make sure that connection protections and/or the mechanical locks will not be removed during the storage;
- storage temperature must be between -20°C and +40°C.

9 INSTALLATION

<p>Warning</p> 	<p>The following instructions must be respected:</p> <ul style="list-style-type: none"> - operations must be carried out only by skilled operators; - always wear protective clothing, gloves, and eyewear to prevent personal injury. Check with your process or safety engineer for any additional measures that must be taken to protect against process media.
---	--

<p>Important</p> 	<p>Not performing the following procedures will invalidate the product warranty.</p>
---	--

9.1 Checks to be performed before installation

It is recommended to check the SC/V valve actuator conditions before the installation, then:

- prepare the necessary tools for the assembly and setting of the unit;
- check that the coupling dimensions meet the specified coupling dimensions;
- clean the SC/V valve actuator surfaces and remove anything that might prevent a perfect adherence with the valve;

9.2 Alignment of the SC/V valve actuator

After installation on the valve:

- check that the SC/V valve actuator are correctly mounted on the valve and the actuator is perfectly aligned with the valve stem;
- make sure that there is no abnormal binding, sticking or jumping in the motion of the system (actuator/applied load) for the whole shaft;

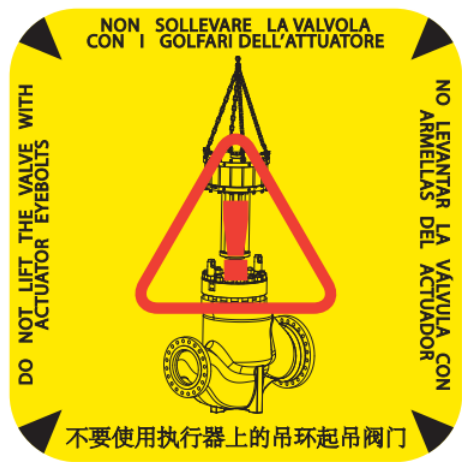
<p>Warning</p> 	<p>Do not lift the valve with the SC/V valve actuator eyebolts</p>	
---	--	--

9.3 Pneumatic connections

Warning 	<p>Check that the values of pneumatic supply available are compatible with those reported on the label of the SC/V valve actuator: a pressure regulator is absolutely necessary when supply pressure is higher than max operating pressure. User must consider and take all precautions to avoid that pressurized parts are not used out of specified range and to avoid exposure to fire.</p>
---	--

Important 	<p>For easier maintenance, it is recommended to install a filter with five micron cartridge and shut-off valve on the supply connection.</p>
---	--

It is required to follow this steps during the pneumatic connection:

- no lubricators on supply fluid line is required;
- use pipes and connections appropriate as for type, rating, material and dimensions;
- properly deburr the ends of rigid pipes;
- properly clean the interior of pipes sending through them plenty of the supply fluid;
- use pipe sealant sparingly and only on male threads. A non-hardening sealant is strongly recommended;
- fasten the connection pipes so that no irregular strains or loosening of threaded connections occur;
- make the pneumatic connections according to the pneumatic diagram;
- check the absence of leakages from pneumatic connections. If necessary tighten the nuts of the pipe-fittings;
- after connecting the actuator, gradually increase the supply pressure up to the maximum operating pressure.

9.4 Earthing connection

Warning 	<p>Check if the SC/V valve actuator has a properly earthing connection.</p>
---	---

The earthing connection is guaranteed through the fixing flange of the SC/V valve actuator. If the earthing connection of the system where SC/V valve actuator is mounted is not guaranteed, it is required to ensure a directly earthing connection.

10 INSTRUCTION FOR THE OPERATORS

<p>Warning</p> 	<p>The following instructions must be respected:</p> <ul style="list-style-type: none"> - operations must be carried out only by skilled operators; - always wear protective clothing, gloves, and eyewear to prevent personal injury. Check with your process or safety engineer for any additional measures that must be taken to protect against process media.
---	--

<p>Important</p> 	<p>Any repair work other than the operations outlines in this Instruction Manual is allowed only if STI S.r.l. authorises it.</p>
---	---

10.1 Field activities

During the start-up of the SC/V valve actuator:

- check that the pressure and quality of the supply fluid (filtering degree, dehydration, etcetera) are as prescribed;
- check if the operating condition are as prescribed;
- check if the actuator is perfectly aligned with the valve stem;
- check that there are no leak of the pneumatic connections;
- check that there are no leak of the accessories mounted on the SC/V valve actuator;
- check that there are no leak of the cylinder of SC/V valve actuator;
- remove all rust on the SC/V valve actuator surfaces;
- repair paint-coat that has been damaged, in accordance with the applicable painting specifications;
- perform a complete functional test.

10.2 Residual Risks

Reasonably foreseeable misuse:

- risk due to movements of loads during transport and installation;
- crushing during transport and installation;
- installation in ambient with not planned conditions;
- metal temperature at high or very low values as consequence of ambient temperature as to be considered as a risk of person injury in case of contact;
- insert incorrect motive fluid into the system;
- supply pressure out of planned range;
- emissions of hazardous substances where dangerous gases are used as motive fluid.

11 MAINTENANCE

<p>Warning</p> 	<p>The following instructions must be respected:</p> <ul style="list-style-type: none">- operations must be carried out only by skilled operators (STI operators or operators qualified by STI are recommended);- always wear protective clothing, gloves, and eyewear to prevent personal injury. Check with your process or safety engineer for any additional measures that must be taken to protect against process media.
---	--

Before any type of operation and/or maintenance is performed, make sure that:

- actuator, accessories and all connected equipment are not under pressure and in safe conditions;
- fluid supply, power or other energy sources and signals are disconnected;
- actuator is free from any mechanism able to move.

11.1 Periodic Inspections and maintenance

Periodic visual inspections are recommended. The user shall:

- plan and provide for a periodic cleaning/maintenance program that will maintain the external surface of the SC/V valve actuator free from excessive layer of dust;
- lubrication the external mechanical devices in motion every six months (see Section 12.3 for the correct grease type);
- check painting status of the entire actuator at least every three months. If any damage on the painting film is present, the user shall immediately carry out an adequate painting touch-up;
- replace the gaskets and the grease every 2- 3 years depending on the actuator operating conditions; see enclosed annexes for any details:
 - o 200-320 Stem Extended – Casting Cylinder;
 - o 200-320 Stem Retracted – Casting Cylinder;
 - o 200-320 RV Stem Retracted – Casting Cylinder;
 - o 300-400-500-520 Stem Extended – No Casting Cylinder;
 - o 300-400-500-520 Stem Retracted – No Casting Cylinder.

11.2 Extraordinary maintenance

In case of extraordinary maintenance, following malfunction and related troubleshooting, proceed as written in Section 13.

11.3 Greases

SC/V cylinder material	Very Low temperature (Tmin ≤ -40°C)	Low temperature (-40°C < Tmin < -20°C)	Standard temperature (-20°C ≤ T ≤ -70°C)	High temperature (Tmax > 70°C)
Aluminum	RHEOLUBE 361F (Tecnolube seal)	RHOESIL 500F (Tecnolube seal)	MOLYGUARD IDROSFER	SYNTHY 101 (Tecnolube seal)
Nickel plated carbon steel	RHEOLUBE 361F (Tecnolube seal)	RHOESIL 500F (Tecnolube seal)	MOLYGUARD IDROSFER	SYNTHY 101 (Tecnolube seal)
Chrome plated carbon steel	RHEOLUBE 361F (Tecnolube seal)	RHOESIL 500F (Tecnolube seal)	POLIMER 400/1 (Tecnolube seal)	SYNTHY 101 (Tecnolube seal)
Stainless steel	RHEOLUBE 361F (Tecnolube seal)	RHOESIL 500F (Tecnolube seal)	POLIMER 400/1 (Tecnolube seal)	SYNTHY 101 (Tecnolube seal)
Fiber	RHEOLUBE 361F (Tecnolube seal)	RHOESIL 500F (Tecnolube seal)	POLIMER 400/1 (Tecnolube seal)	SYNTHY 101 (Tecnolube seal)

Manual override material	Very Low temperature (Tmin ≤ -40°C)	Low temperature (-40°C < Tmin < -20°C)	Standard temperature	High temperature (Tmax > 70°C)
All material	MOLIKOTE	MU EP (Agip)	MU EP (Agip)	MU EP (Agip)

12 PARTS LIST GENERAL ASSEMBLY

12.1 Stem Extended + Casting Actuator

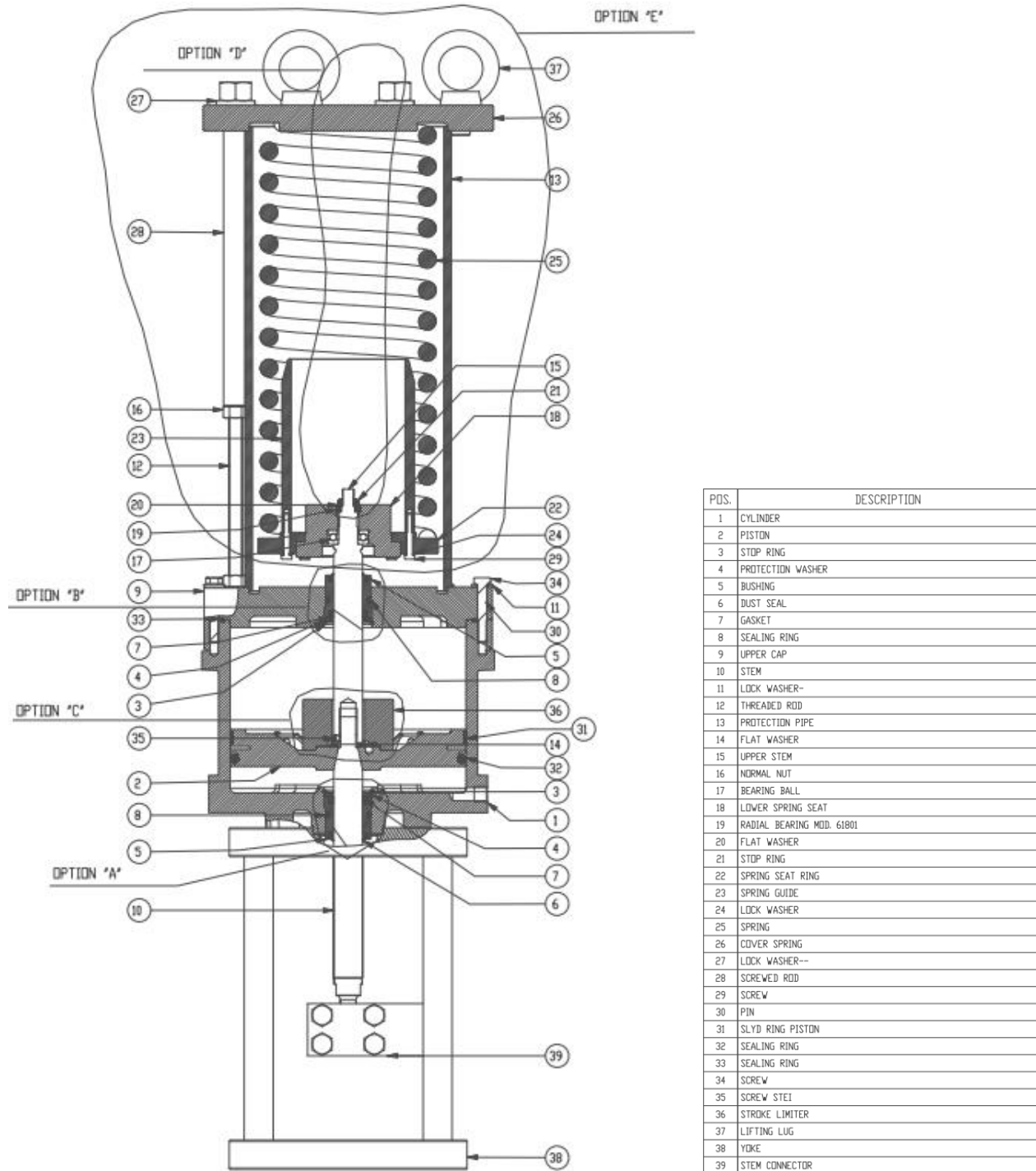

Figure 4 – Stem Extended Casting Actuator: typical design

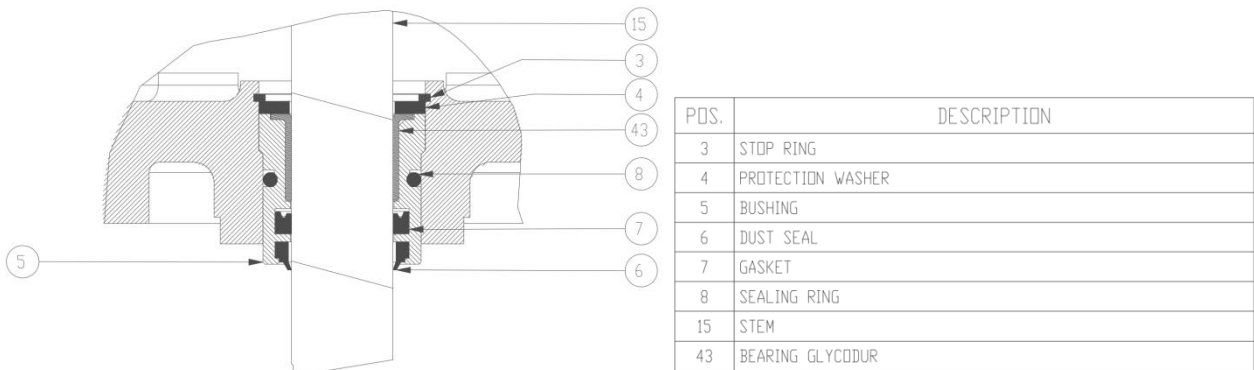

Figure 5 – Stem Extended Casting Actuator: option A

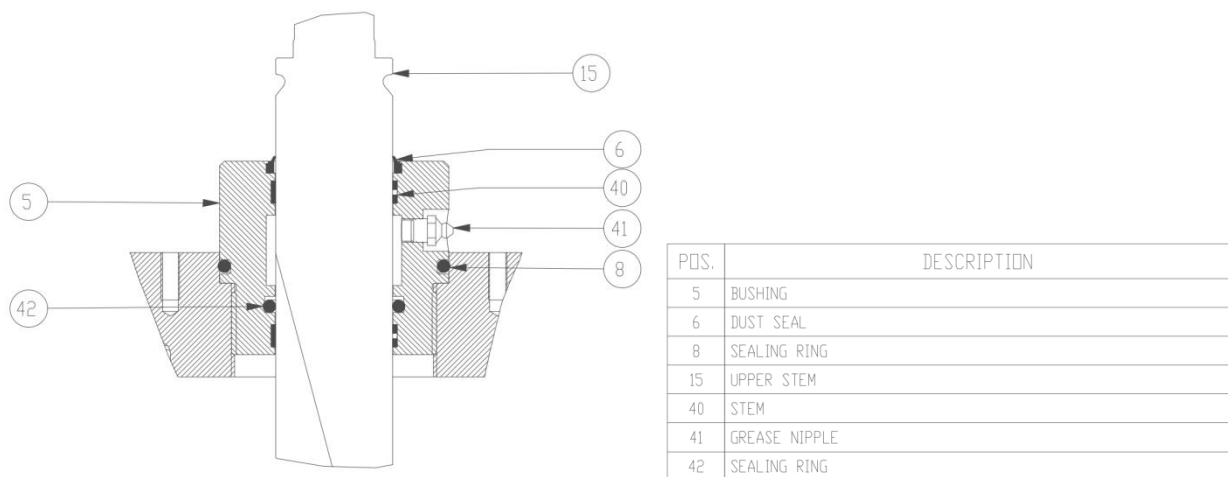

Figure 6 – Stem Extended Casting Actuator: option B

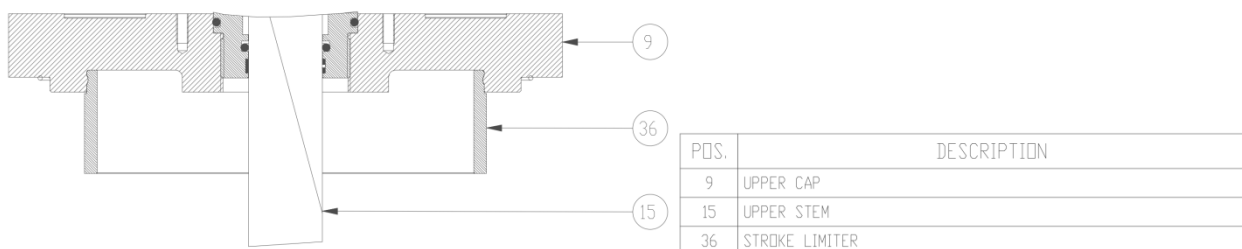
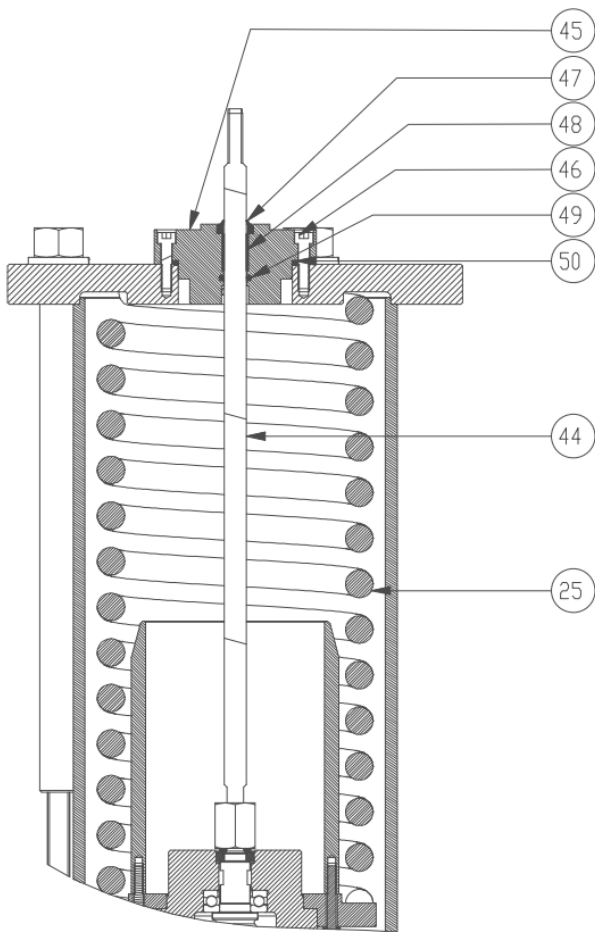

Figure 7 – Stem Extended Casting Actuator: option C



PDS.	DESCRIPTION
25	SPRING
44	STEM CONTROL LEVER
45	COUPLING FLANGE
46	SCREW
47	DUST SEAL
48	BEARING
49	SEALING RING
50	SEALING RING

Figure 8 – Stem Extended Casting Actuator: option D

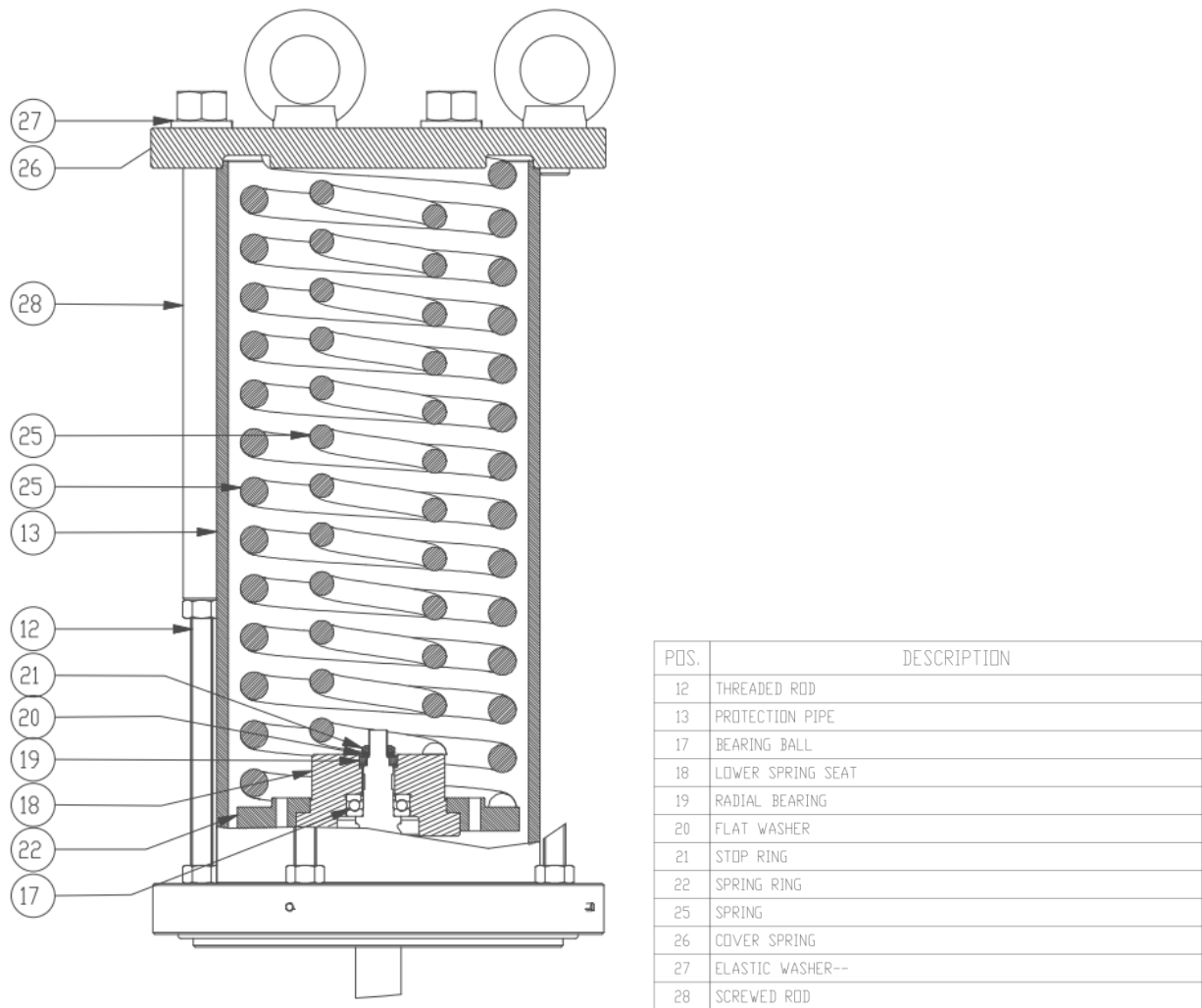

Figure 9 – Stem Extended Casting Actuator: option E

12.2 Stem Extended + No Casting Actuator

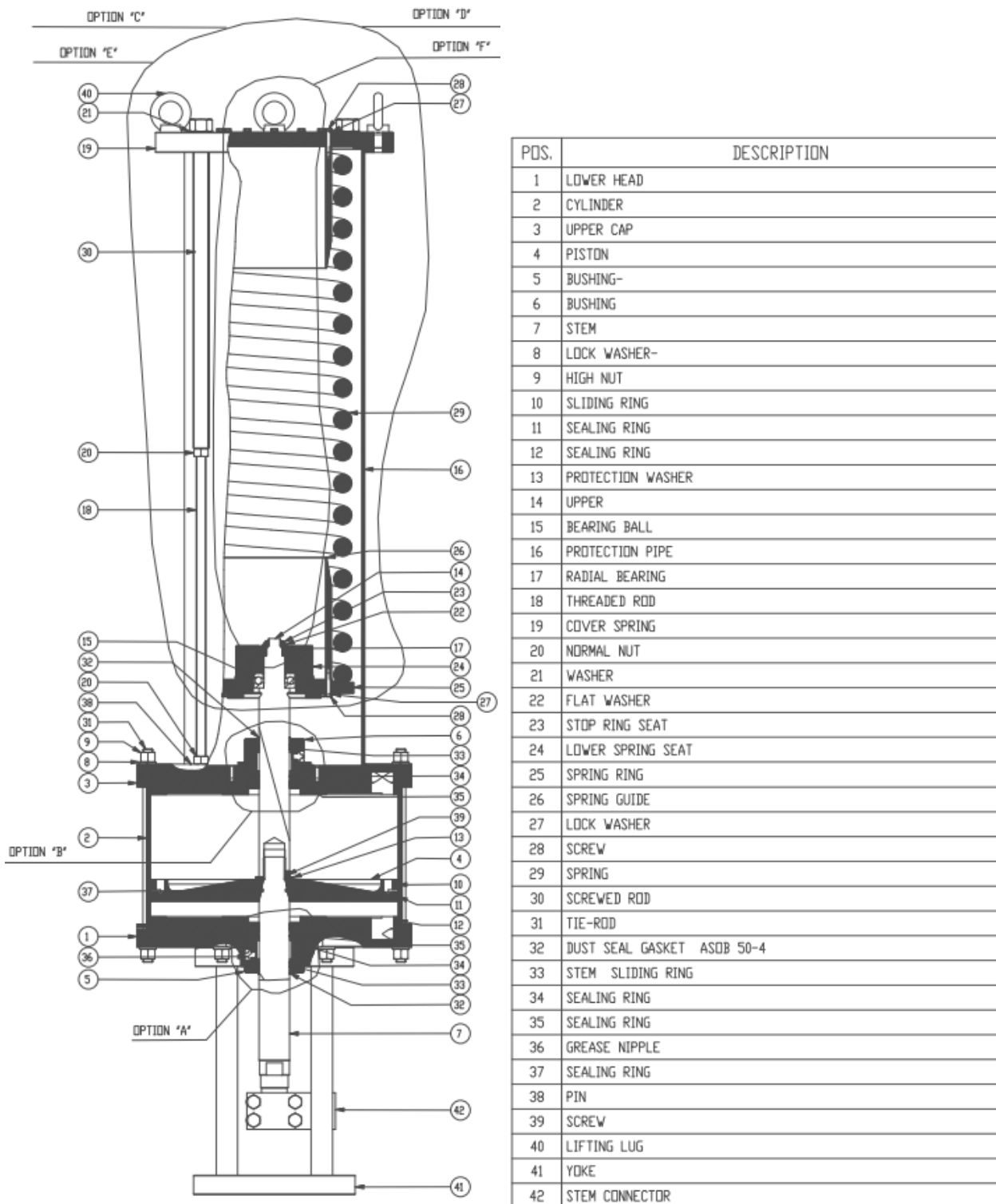
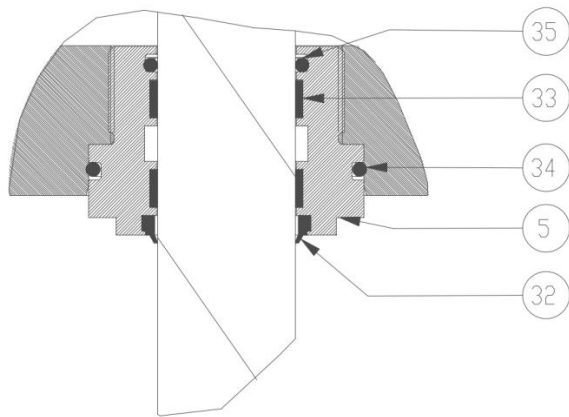
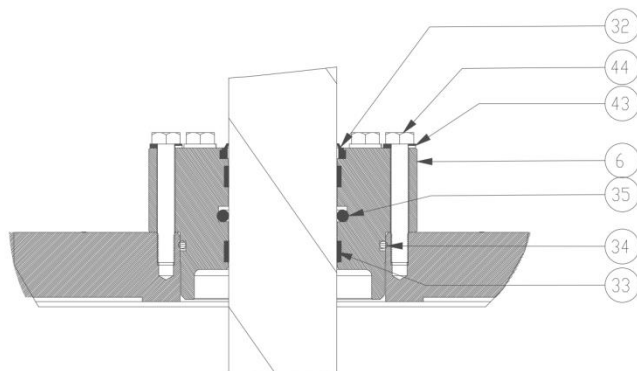

Figure 10 – Stem Extended No Casting Actuator: typical design



PDS.	DESCRIPTION
5	BUSHING
32	DUST SEAL
33	STEM SLIDING RING
34	SEALING RING
35	SEALING RING

Figure 11 – Stem Extended No Casting Actuator: option A



PDS.	DESCRIPTION
6	COUPLING FLANGE
32	DUST SEAL
33	STEM SLIDING RING
34	SEALING RING
35	SEALING RING
43	LOCK WASHER
44	SCREW

Figure 12 – Stem Extended No Casting Actuator: option B

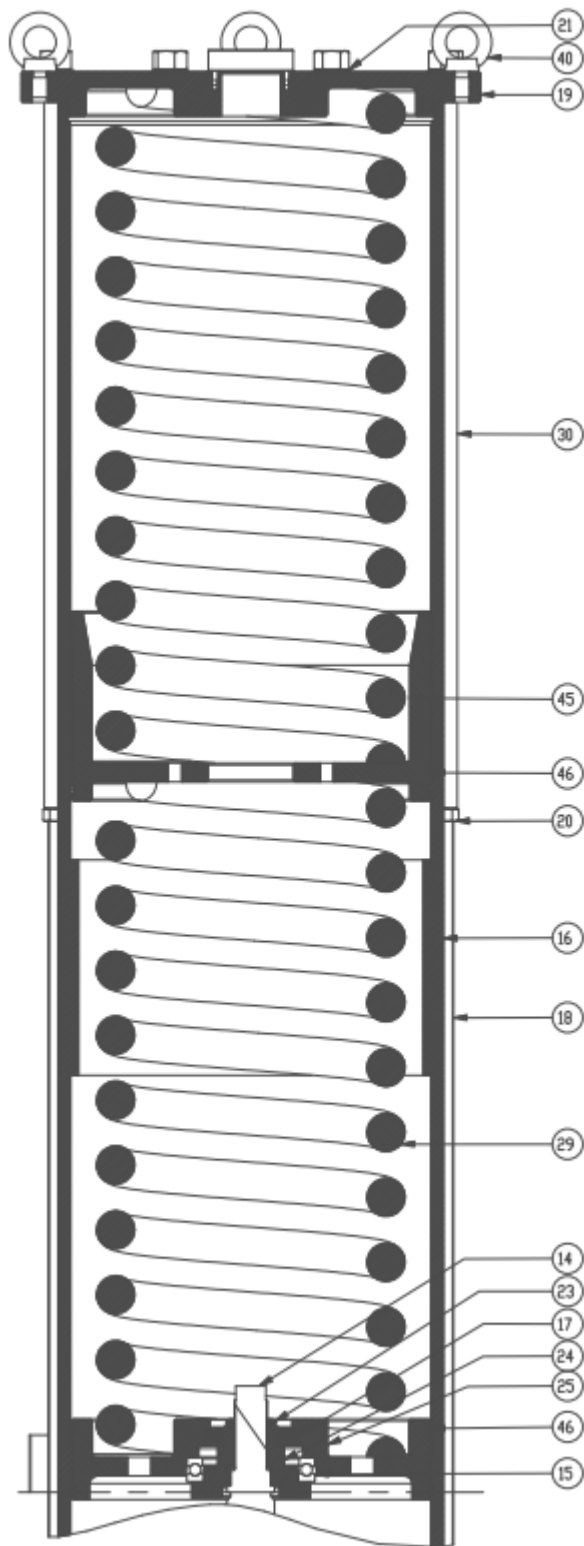

POS.	DESCRIPTION
14	UPPER STEM
15	BEARING BALL
16	PROTECTIO PIPE
17	RADIAL BEARING
18	THREADED ROD
19	COVER SPRING
20	NORMAL NUT
21	WASHER
23	RING NUT
24	LOWER SPRING SEAT
25	SPRING RING SEAT
46	SLIDING RING
29	SPRING
30	SCREWED ROD
40	LIFTING LUG
45	SPRING GUIDE

Figure 13 – Stem Extended No Casting Actuator: option C

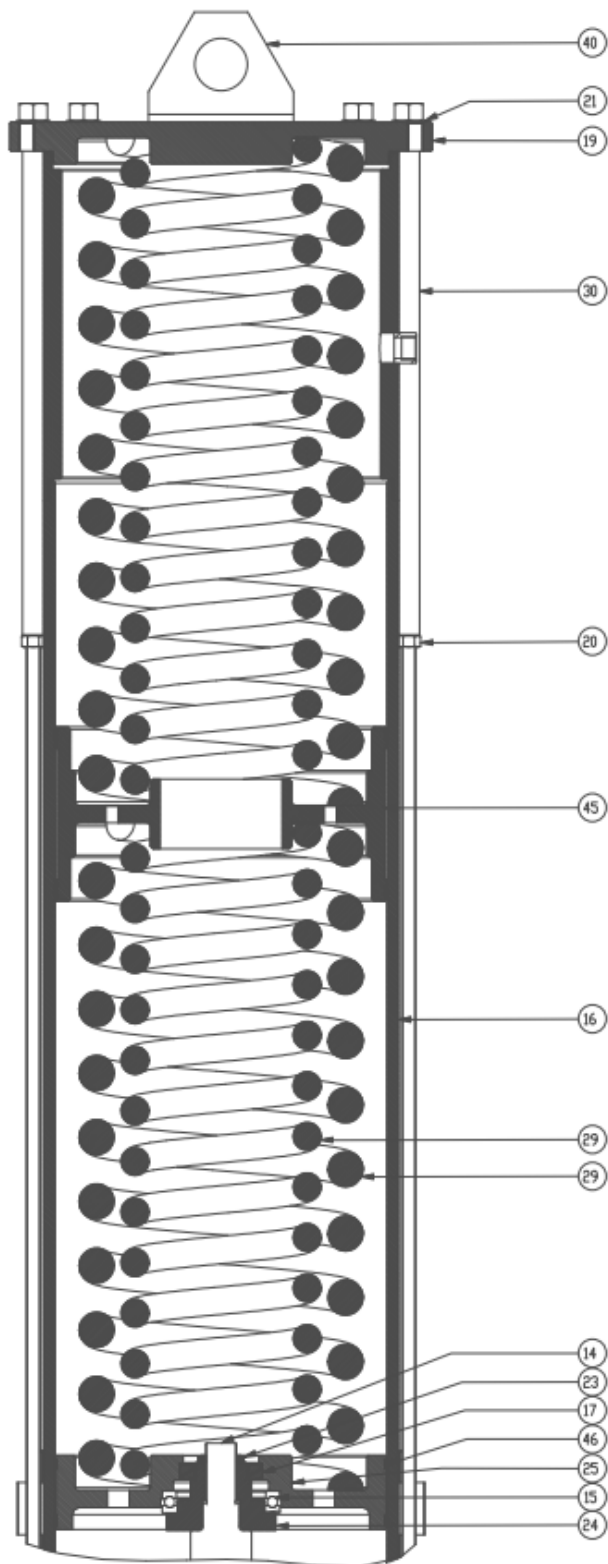

POS.	DESCRIPTION
14	UPPER STEM
15	BEARING BALL
16	PROTECTIN PIPE
17	RADIAL BEARING
19	COVER SPRING
20	NORMAL NUT
21	WASHER
23	RING NUT
24	LOWER SPRING SEAT
25	SPRING RING SEAT
29	SPRING
30	SCREWED ROD
40	LIFTING LUG
45	GUIDE SPRING INTERMEDIATE
46	SLIDING RING

Figure 14 – Stem Extended No Casting Actuator: option D

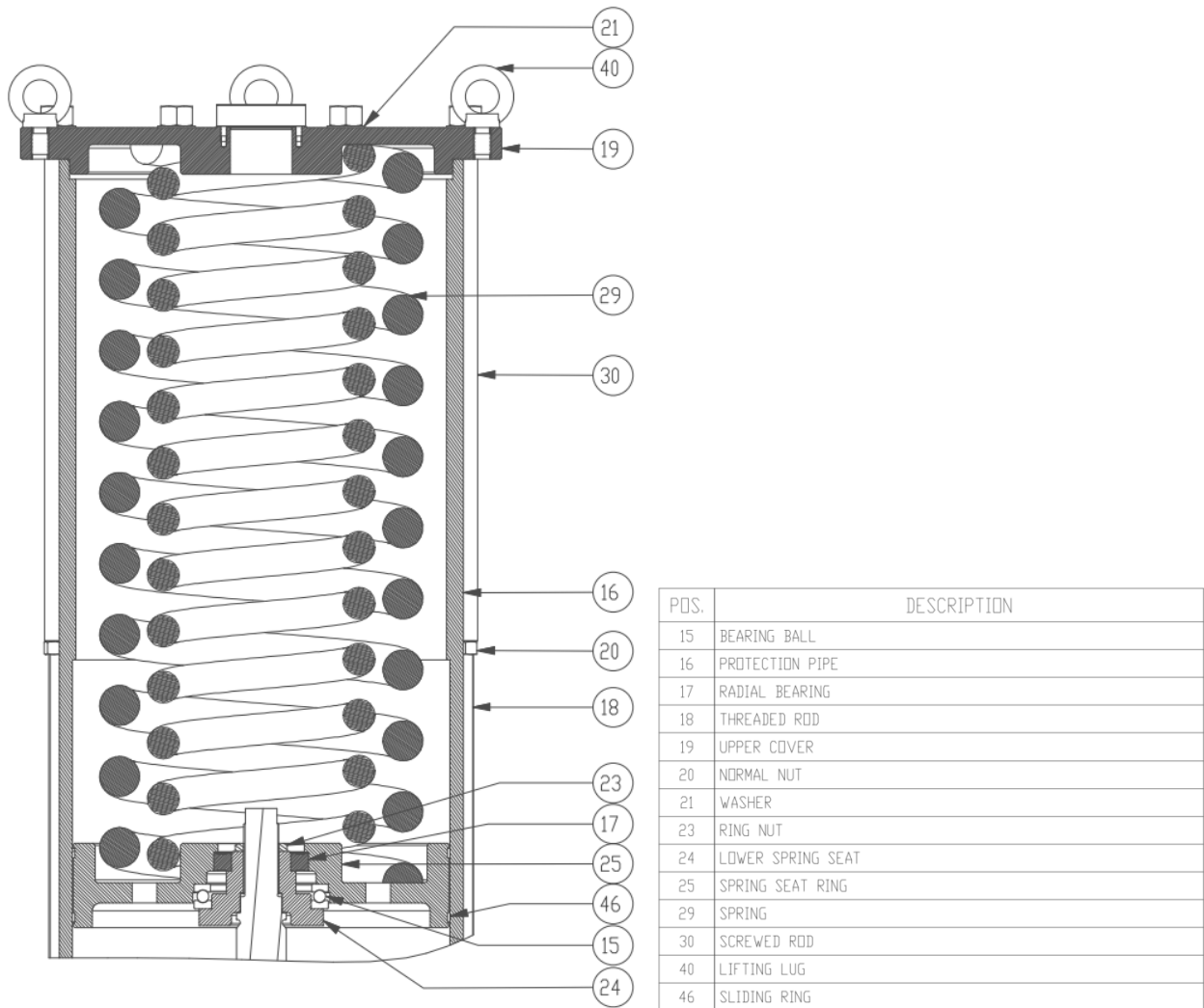
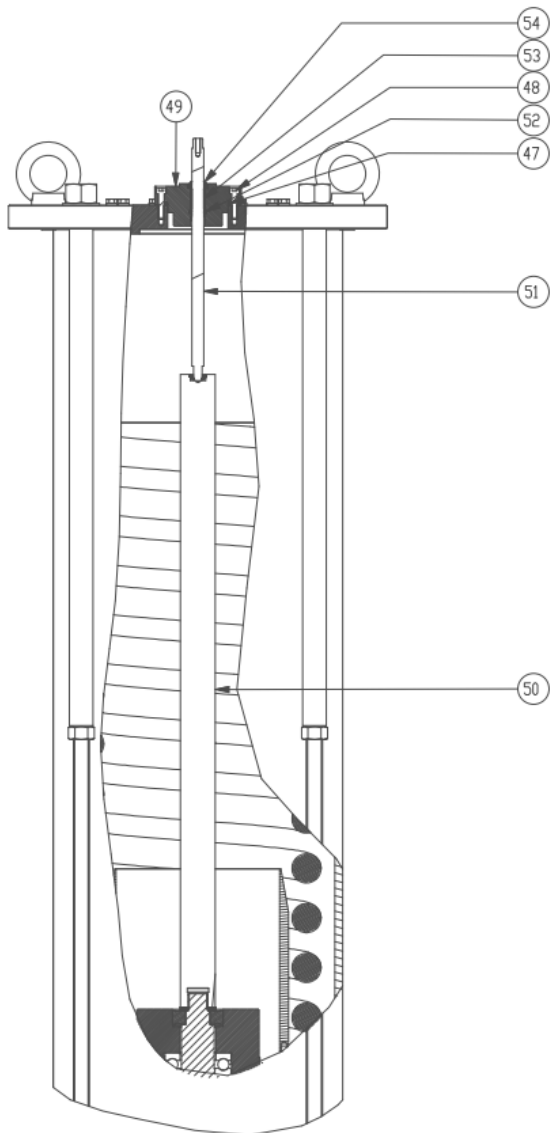

Figure 15 – Stem Extended No Casting Actuator: option E



PDS.	DESCRIPTION
47	SEALING RING
48	SCREW
49	COUPLIG FLANGE
50	SPACER STEM
51	STEM CONTROL LEVER
52	SEALING RING
53	BEARING
54	DUST SEAL

Figure 16 – Stem Extended No Casting Actuator: option F

12.3 Stem Retracted + Casting Actuator

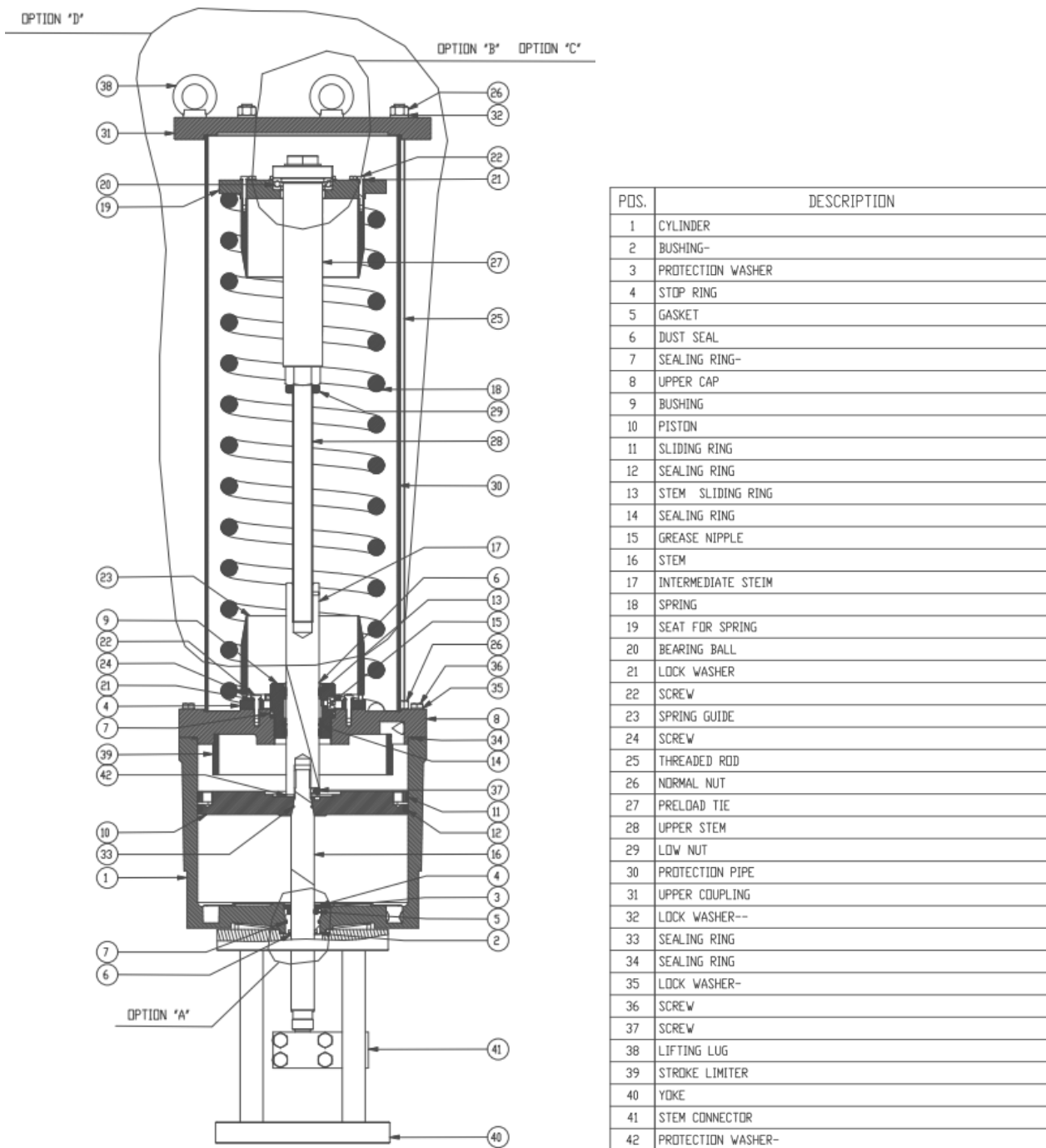
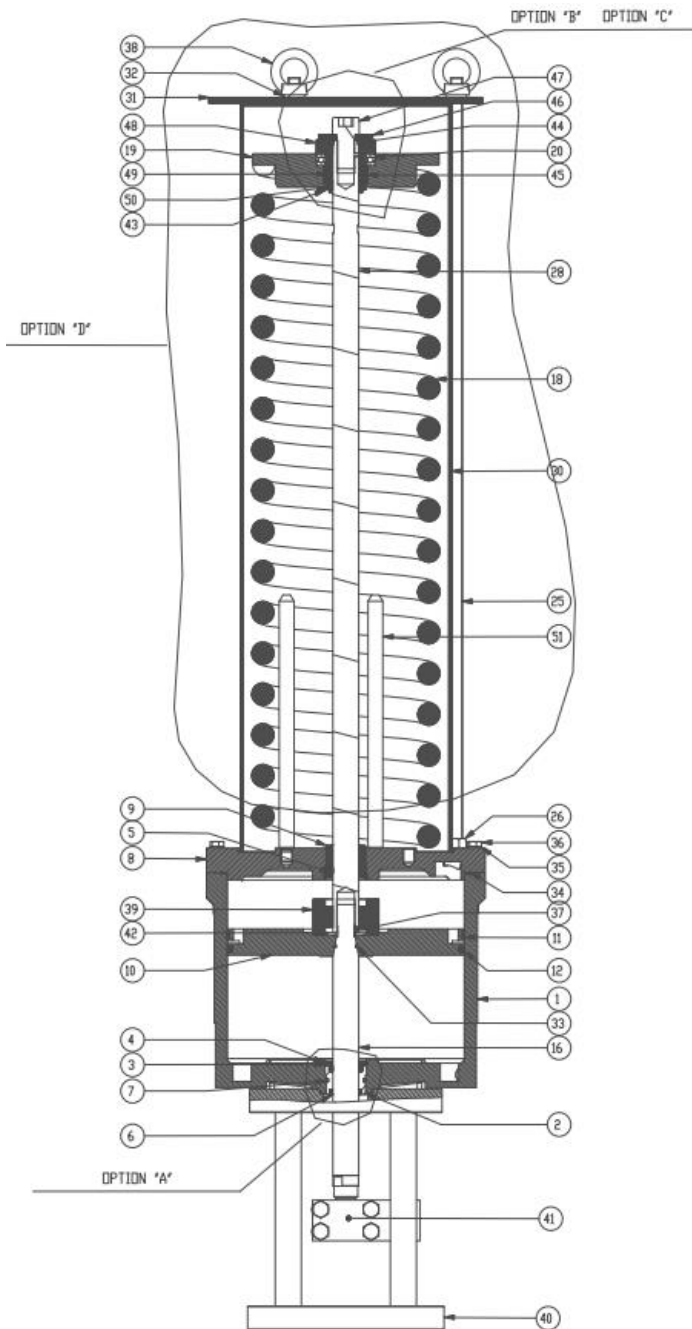
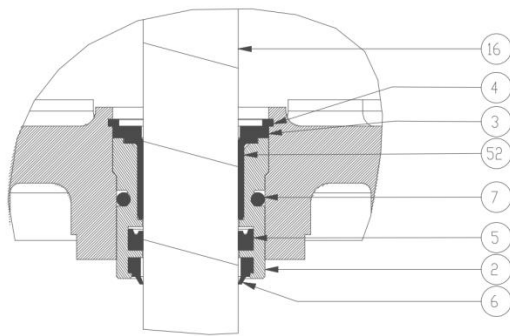

Figure 17 – Stem Retracted Casting Actuator: typical design 1



PDS.	Q.TY'	DESCRIPTION
1	1	CYLINDER
2	1	BUSHING
3	2	PROTECTION WASHER
4	2	STOP RING
5	2	GASKET
6	2	DUST SEAL
7	2	SEALING RING
8	1	UPPER CAP
9	1	BUSHING
10	1	PISTON
11	1	SLIDING RING
12	1	SEALING RING
16	1	STEM
18	1	SPRING
19	1	SUPPORT SPRING
20	1	BEARING BALL
25	4	THREADED ROD
26	4	NORMAL NUT
28	1	UPPER STEM
30	1	PROTECTION PIPE
31	1	UPPER COUPLING
32	4	LOCK WASHER--
33	1	SEALING RING
34	1	SEALING RING
35	12	ELASTIC WASHER
36	12	SCREW
37	3	SCREW
38	4	LIFTING LUG
39	1	STROKE LIMITER
40	1	COLUMN YOKE
41	1	STEM CONNECTOR
42	1	PROTECTION WASHER-
43	1	STOP RING-
44	1	STOP RING--
45	1	BEARING
46	1	FLAT WASHER
47	1	VITE
48	1	FLANGE
49	1	INTERNAL RING
50	1	SPACER
51	3	COLUMN GUIDE SPRING

Figure 18 – Stem Retracted Casting Actuator: typical design 2



POS.	DESCRIPTION
2	BUSHING
3	PROTECTION WASHER
4	STOP RING
5	GASKET
6	DUST SEAL
7	SEALING RING
16	STEM
52	BEARING GLYCODUR

Figure 19 – Stem Retracted Casting Actuator: option A

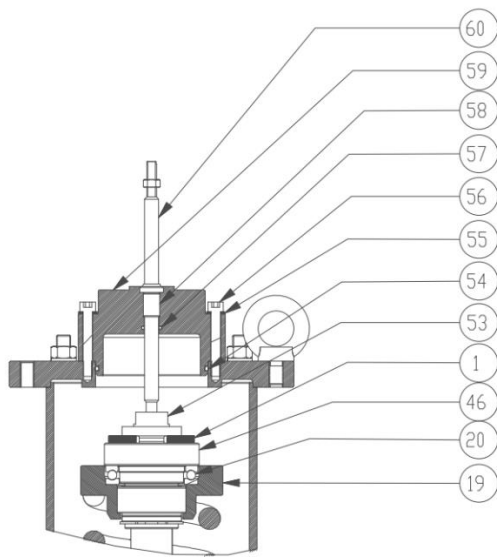

POS.	DESCRIPTION
19	SUPPORT SPRING
20	BEARING BALL
46	FLAT WASHER
48	FLANGE
53	SPECIAL SCREW
54	SEALING RING
55	LOCK WASHER
56	SCREW
57	SEALING RING
58	BEARING
59	COUPLING FLANGE
60	STEM CONTROL LEVEL

Figure 20 – Stem Retracted Casting Actuator: option B

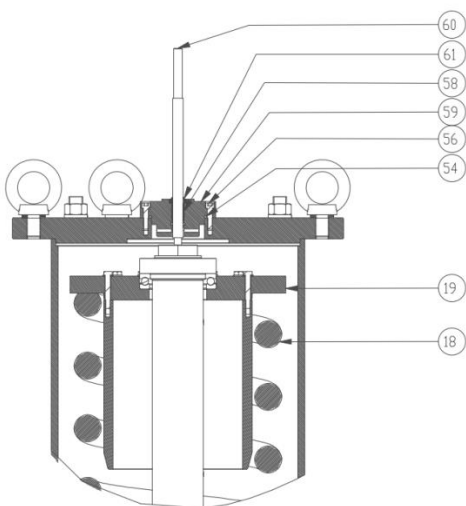

POS.	DESCRIPTION
18	SPRING
19	SEAT FOR SPRING
54	SEALING RING
56	SCREW
58	BEARING
59	COUPLING FLANGE
60	STEM CONTROL LEVER
61	DUST SEAL

Figure 21 – Stem Retracted Casting Actuator: option C

PDS.	Q.TY'	DESCRIPTION
1	2	SPRING

PDS.	Q.TY'	DESCRIPTION
1	2	SPRING

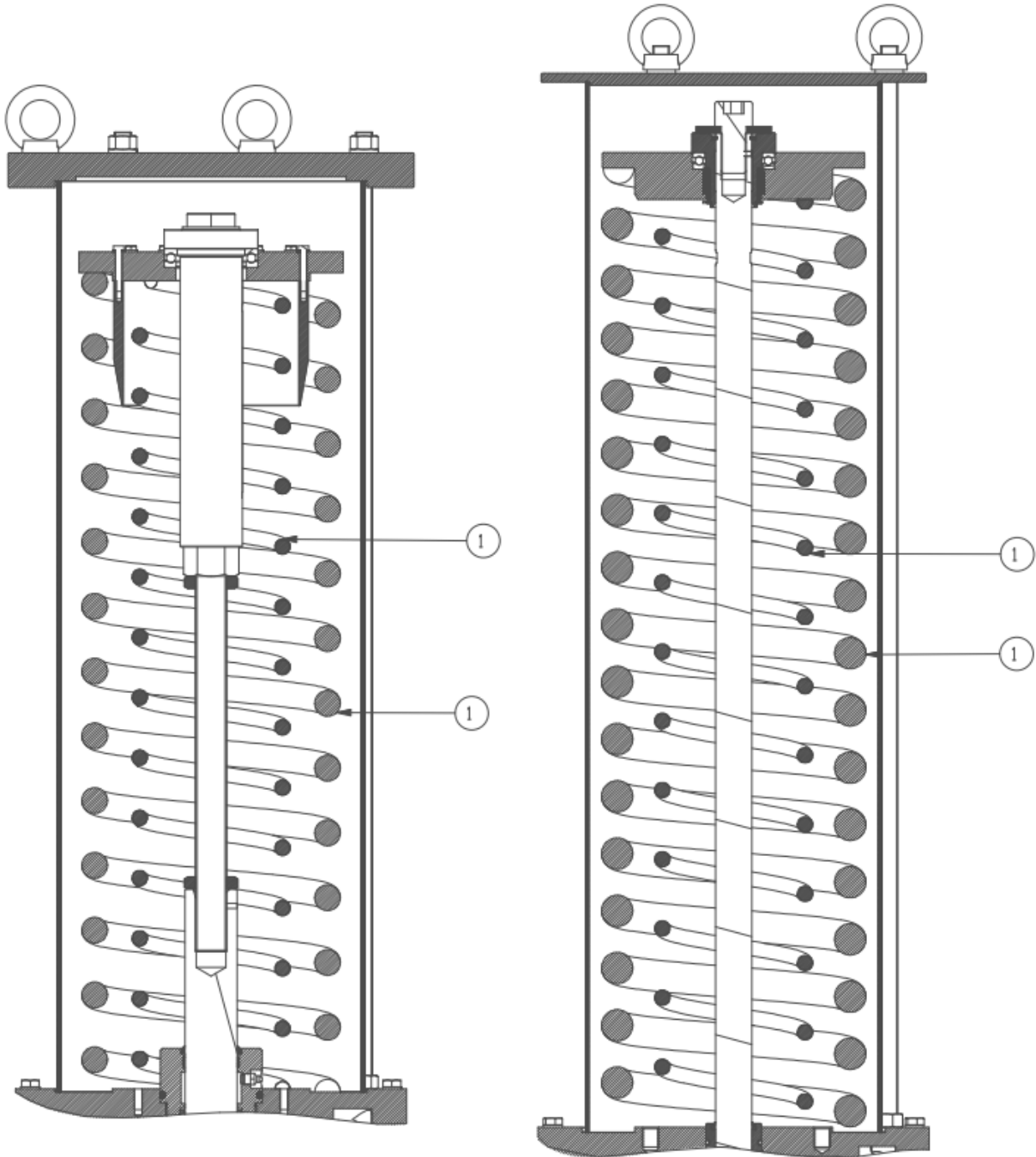

Figure 22 – Stem Retracted Casting Actuator: option D

12.4 Stem Retracted + No Casting Actuator

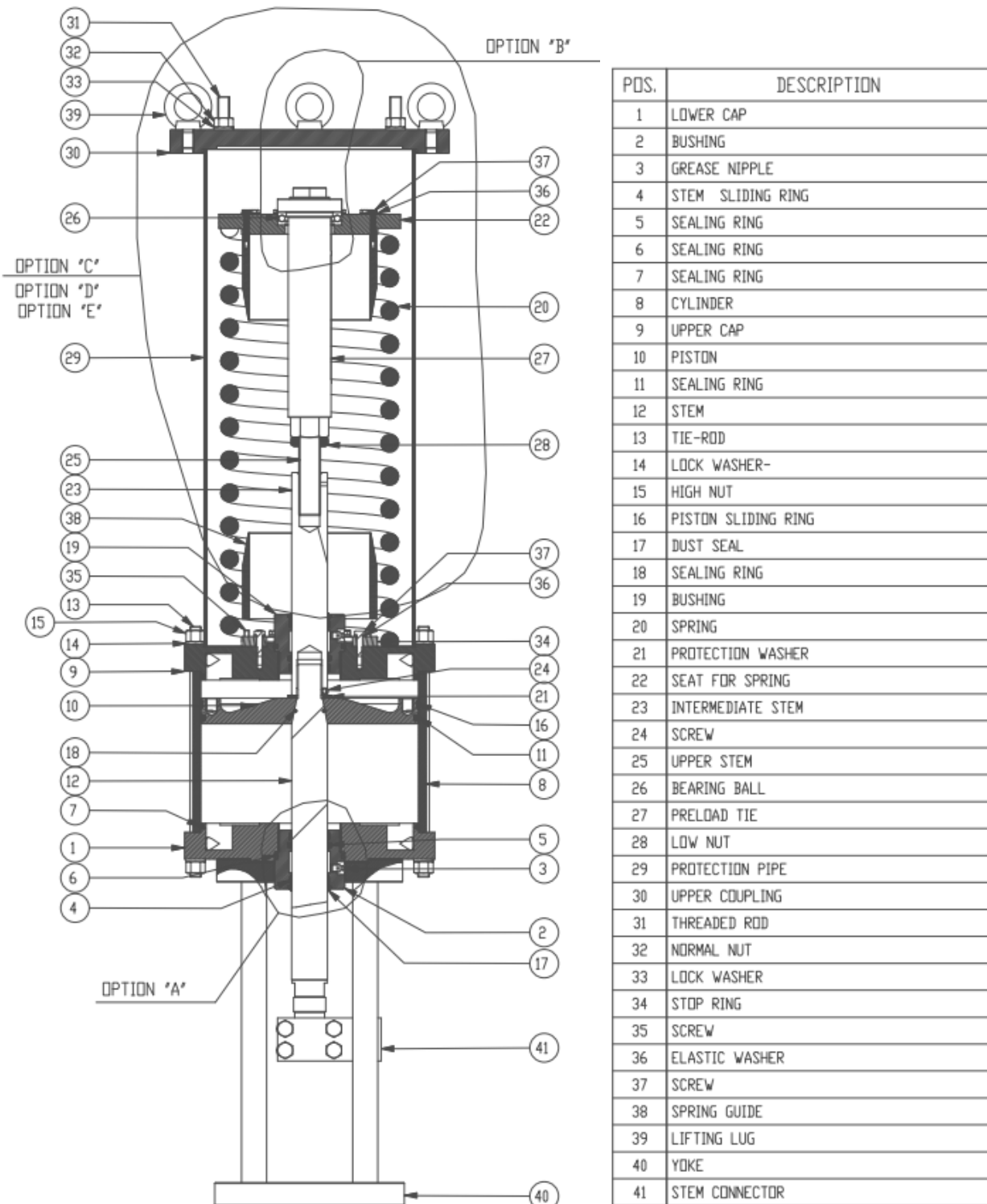

Figure 23 – Stem Retracted No Casting Actuator: typical design

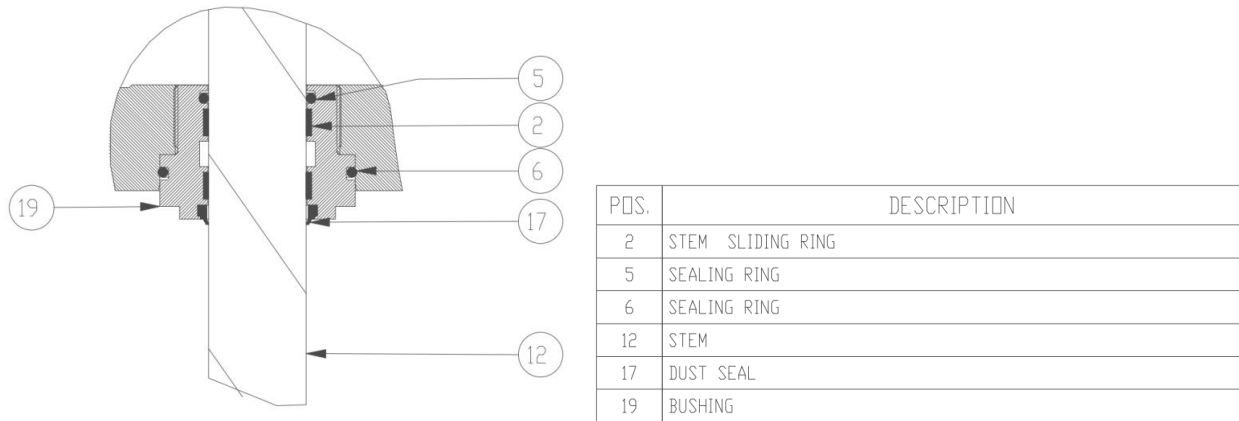

Figure 24 – Stem Retracted No Casting Actuator: option A

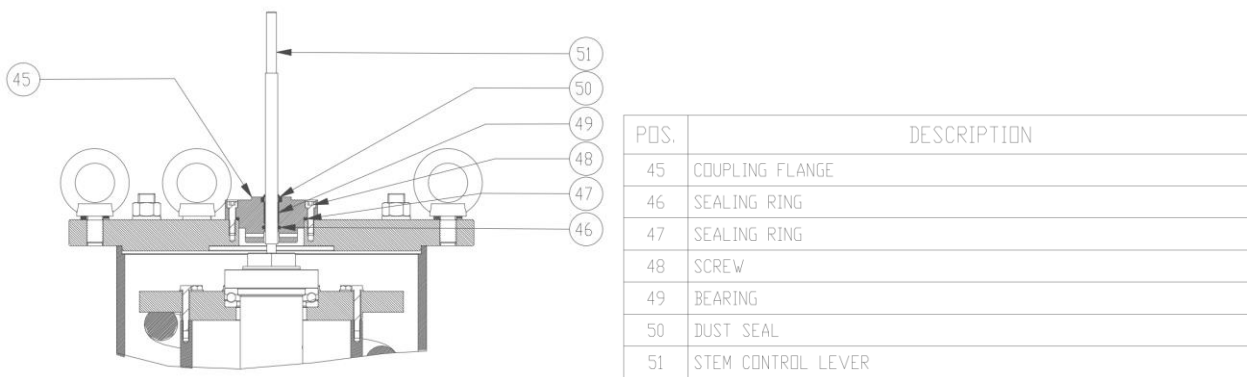
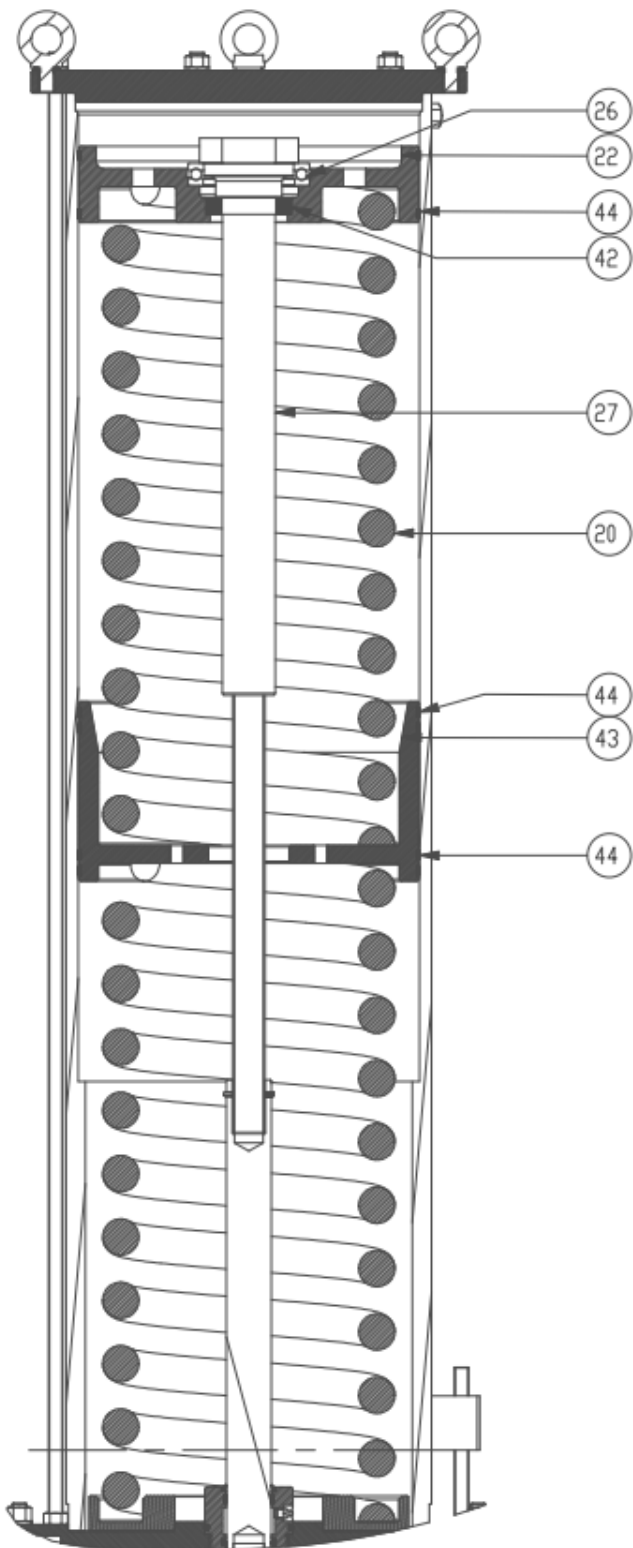
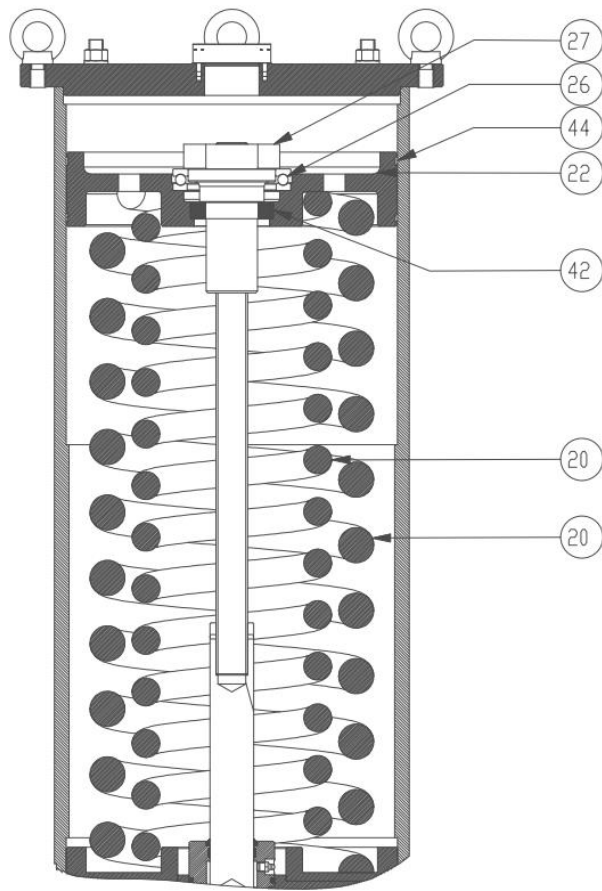

Figure 25 – Stem Retracted No Casting Actuator: option B



POS.	DESCRIPTION
20	SPRING
22	SEAT FOR SPRING
26	BEARING BALL
27	PRELOAD TIE
42	RADIAL BEARING
43	SPRING GUIDE
44	SLIDING RING-

Figure 26 – Stem Retracted No Casting Actuator: option C



POS.	DESCRIPTION
20	SPRING
22	SEAT FOR SPRING
26	BEARING BALL
27	CONNECTOR
42	RADIAL BEARING
44	SLIDING RING-

Figure 27 – Stem Retracted No Casting Actuator: option D

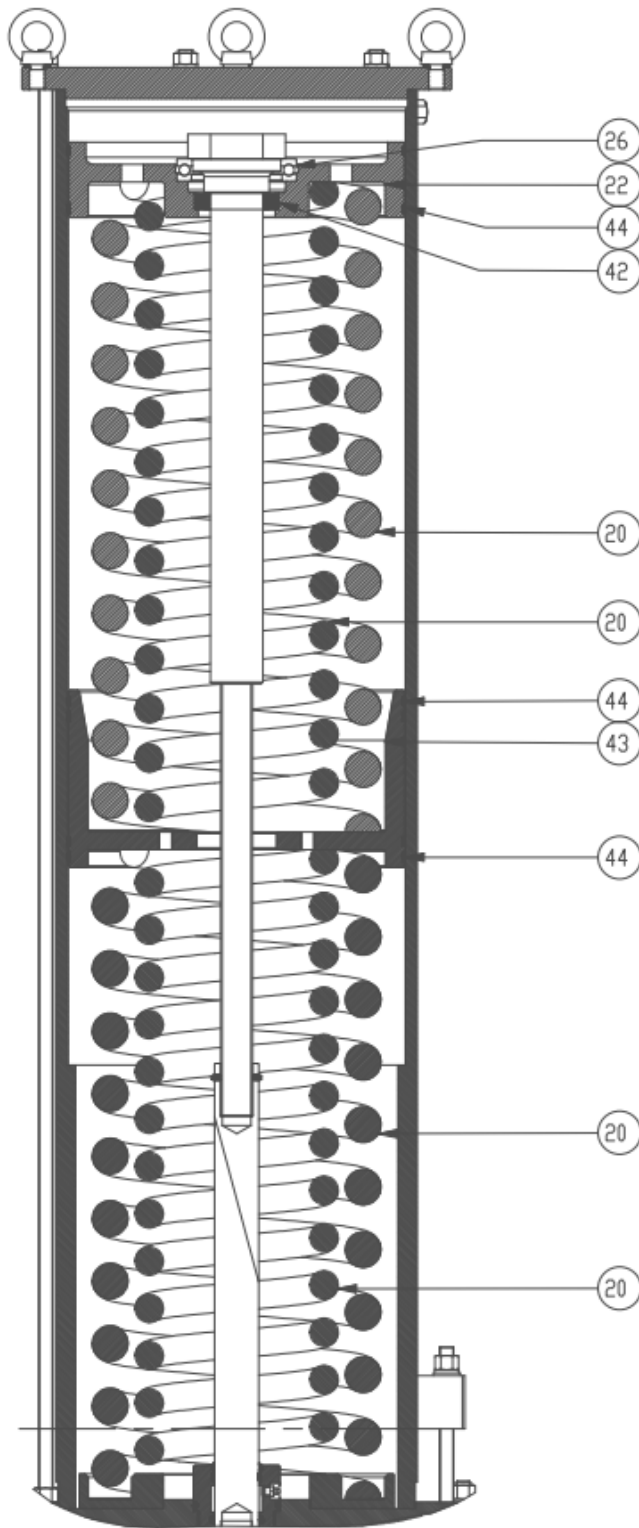

POS.	DESCRIPTION
20	SPRING
22	SEAT FOR SPRING
26	BEARING BALL
42	RADIAL BEARING
43	SPRING GUIDE
44	SLIDING RING-

Figure 28 – Stem Retracted No Casting Actuator: option E

13 TROUBLESHOOTING

EVENT	POSSIBLE CAUSE	REMEDY
SC/V valve actuator doesn't move	Lack of pneumatic supply	Check supply line
	Low supply pressure	Adjust supply pressure
	Pneumatic circuit failure	Call STI S.r.l.
	Thrust on stem not enough (valve seizing)	Call valve manufacturer
	Thrust on stem not enough (wrong actuator sizing)	Call STI S.r.l.
	Presence of an external obstruction	Put the SC/V valve actuator in a safety condition and remove the obstruction
	Damaged actuator internal component	Call STI S.r.l.
SC/V valve actuator doesn't move in a linear way	Lubricators unsuitable	Replace the lubricators
		Call STI S.r.l.
	Stem misalignment	Check the actuator stem alignment
		Call STI S.r.l.
	Thrust on stem not enough (valve seizing)	Call valve manufacturer
Thrust on stem not enough (wrong actuator sizing)	Call STI S.r.l.	
Opening/Closing time not satisfy	Incorrect positioner calibration	Call STI S.r.l.
	Pneumatic circuit not suitable	Call STI S.r.l.
	Wrong actuator sizing	Call STI S.r.l.
	Wrong spring selection	Call STI S.r.l.
	Spring vent clogging (if any)	Check the spring vent
Leakages from pneumatic cylinder	Deterioration and/or damage of gasket	Replace the gaskets
		Call STI S.r.l.
	Deterioration and/or damage of the cylinder or the upper/lower cap	Call STI S.r.l.
Incorrect tie rods tighten	Call STI S.r.l.	
Leakages from pneumatic circuit	The nuts of pipe fittings are not tighten enough	Tighten the nuts
	An accessory does not work correctly	Call STI S.r.l.

Important 	<p>If another event happens or another possible cause of the above events has been detected, call STI S.r.l.</p>
---	---

14 SPARE PARTS

Contact STI S.r.l. for the gasket kit required for the gaskets replacement. Other spare parts can be sent to the customer if required.

15 DISASSEMBLING

<p>Important</p> 	<p>The customer can disassemble the SC/V valve actuator only for the gaskets/grease replacement (see Section 11). In other cases, the disassembling is not allowed if it is not authorized by STI.</p>
---	--

16 DECOMMISSIONING

<p>Warning</p> 	<p>The following instructions must be respected:</p> <ul style="list-style-type: none"> - operations must be carried out only by skilled operators; - always wear protective clothing, gloves, and eyewear to prevent personal injury. Check with your process or safety engineer for any additional measures that must be taken to protect against process media.
---	--

<p>Important</p> 	<p>Check local authority regulation before disposal.</p>
--	--

SUBJECT	HAZARDOUS	RECYCABLE	DISPOSAL
Metals	No	Yes	Use licensed recyclers
Plastics	No	Yes	Use specialist recyclers
Rubber (seals, o-rings)	Yes	No	May require special treatment before disposal, use specialist waste disposal companies
Oil and grease	Yes	Yes	May require special treatment before disposal, use specialist waste disposal companies

ANNEX A_SC/V200-320: Stem Ext. + Casting Cyl.

GASKETS REPLACEMENT

SC/V 200-320: Stem Extended + Casting Cylinder

<p>Warning</p> 	<p>The following instructions must be respected:</p> <ul style="list-style-type: none"> - operations must be carried out only by qualified staff (STI operators or operators qualified by STI are recommended); - always wear protective clothing, gloves, and eyewear to prevent personal injury. Check with your process or safety engineer for any additional measures that must be taken to protect against process media.
---	--

During the gaskets replacement:

- take care to not damage gaskets grooves during maintenance;
- use only the grease type shown in the enclosed table.

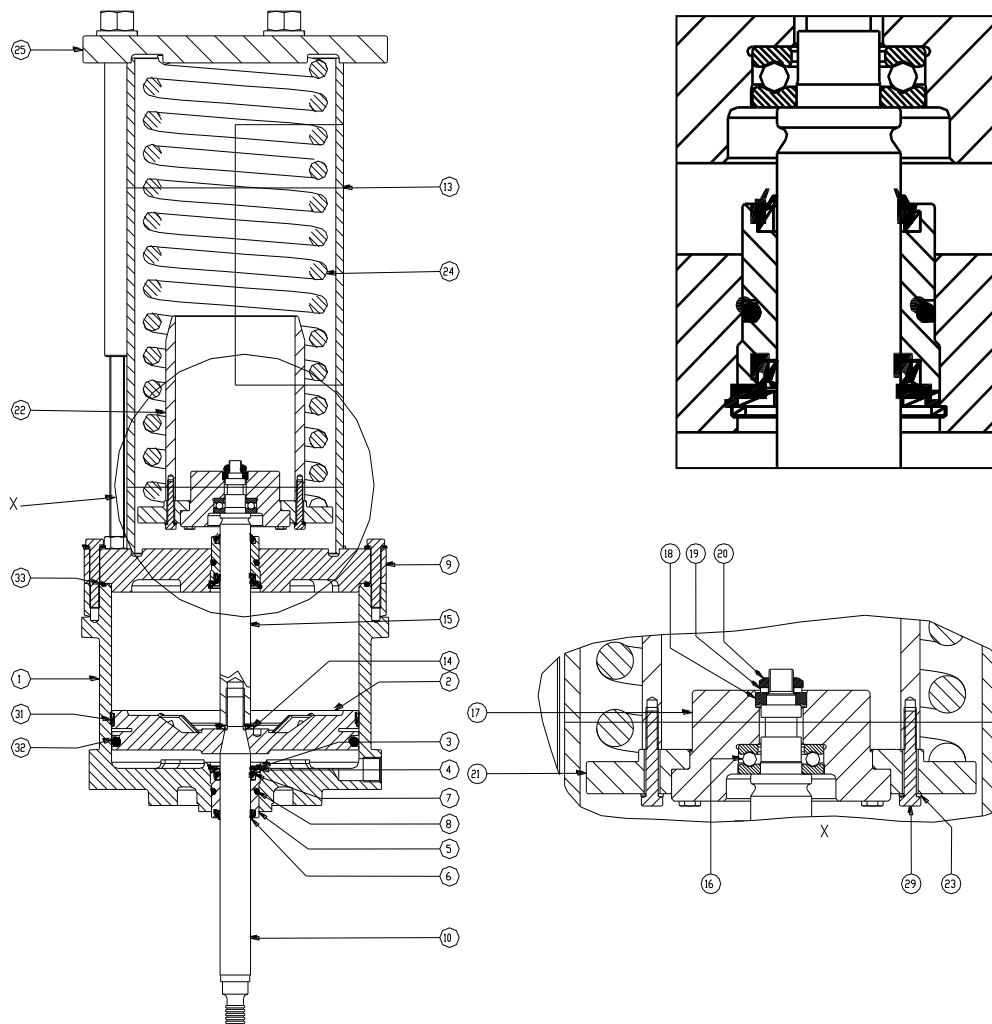

Disassembling:

- 9.1 Disconnect the actuator from the air supply and ensure the actuator is not pressurized.
- 9.2 Disconnect the actuator stem from the valve stem.
- 9.3 Disassemble the spring protection upper cover (pos.25) by unscrewing the tie rods and removing all the accessories/fittings where needed.

<p>Warning</p> 	<p>Pay attention at the spring action.</p>
---	---

- 9.4 Remove the spring protection cylinder (pos.13).
- 9.5 Remove the spring (pos.24).
- 9.6 While holding the stem (pos.10) unscrew the ring nut (pos.20).
- 9.7 Remove the spring guide and register (pos.17/21/22) and the bearing (pos.16).
- 9.8 Remove the upper cover of the actuator (pos.9) by unscrewing the screws.
- 9.9 Pull the piston (pos.2) and the piston (pos.15/10) from the cylinder (pos.1).
- 9.10 Remove the o-ring (pos. 33) from the cylinder
- 9.11 Remove sliding ring (pos.31) and o-ring (pos.32) from the piston.
- 9.12 Remove snap ring (pos.3) and push the bushing (pos.5) towards the inside of the actuator and remove the gaskets (pos.6,7 and 8).
- 9.13 Repeat the same procedure as 9.12 for upper cover bushing (pos.9).

Replacement:

- 9.14 Clean the actuator parts with a mild detergent suitable for grease removal using a brush, then dry with a cloth and compressed air.
- 9.15 Apply grease on the rough parts of back cylinder. Do not apply grease on the machined surfaces.
- 9.16 Apply grease to the o-ring and install them on the bushings. Insert and fix the bushings into the cover and cylinder.
- 9.17 Fill the grease reservoir along the outer rim of the piston.

<p>Important</p> 	<p>Apply grease to the gaskets prior installation.</p>
---	---

- 9.18 Install new gaskets kit.
- 9.19 Apply grease to the inside surface of the cylinder.
- 9.20 Install the sliding ring on the piston.
- 9.21 Install the o-ring on the piston and remove the excess grease.
- 9.22 Insert the piston into the actuator cylinder. Take care of the mounting direction.
- 9.23 Mount the upper cover on the actuator, torque the screws to the values indicated on the table below.
- 9.24 Install the spring guide components (pos.17/21/22) with the bearing (pos.16) and spacers (pos.18/19), tighten the ring nut (pos.20).
- 9.25 Install the spring (pos.24) on the guide.
- 9.26 Install the protection cylinder (pos.13) and cover (pos.25), tighten the tie rods.
- 9.27 Test the piston movement using an air gun.
- 9.28 Plumb all pneumatic connections and check for air leaks at 1 bar (0,1 MPa) air supply pressure. If there are no leaks, repeat the test at 7 bar (0,7 MPa).
- 9.29 Clean the excess grease from the shaft.

SC/V	Torque [Nm]
200	14 (10,3 lbf-ft)
320	20 (14,7 lbf-ft)

ANNEX B_SC/V200-320: Stem Retr. + Casting Cyl.

GASKETS REPLACEMENT

SC/V 200-320: Stem Retracted + Casting Cylinder

<p>Warning</p> 	<p>The following instructions must be respected:</p> <ul style="list-style-type: none"> - operations must be carried out only by qualified staff (STI operators or operators qualified by STI are recommended); - always wear protective clothing, gloves, and eyewear to prevent personal injury. Check with your process or safety engineer for any additional measures that must be taken to protect against process media.
---	--

During the gaskets replacement:

- take care to not damage gaskets grooves during maintenance;
- use only the grease type shown in the enclosed table.

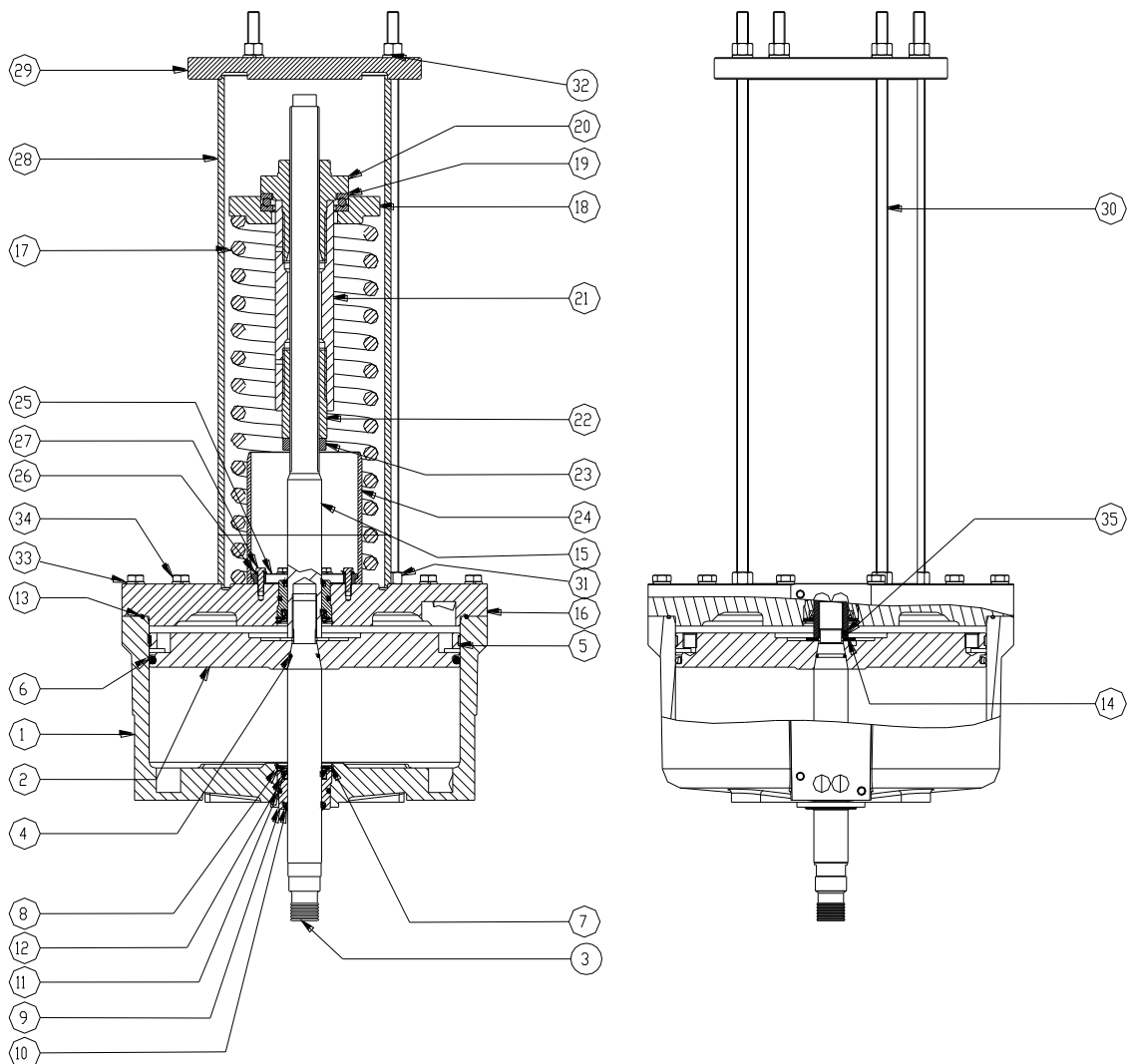

Disassembling:

- 9.1 Disconnect the actuator from the air supply and ensure the actuator is not pressurized.
- 9.2 Disconnect the actuator stem from the valve stem.
- 9.3 Disassemble the spring protection upper cover (pos.30) by unscrewing the nuts (pos.32) and removing all the accessories/fitings where needed.
- 9.4 Remove the spring protection cylinder (pos.28).
- 9.5 Mark with a pen the internal screwed shaft (pos.21/22) position with the screw (pos.15).
- 9.6 Prevent the shaft (pos.15) from rotating while removing the spring preloader (pos.21/22).
- 9.7 Remove the spring register (pos.18) and the spring (pos.17).
- 9.8 Remove the upper cover of the actuator (pos.16) by removing the screws (pos.34).
- 9.9 Pull the shaft (pos.3) and the piston (pos.2) out from the cylinder (pos.1).
- 9.10 Take the o-ring (pos. 13) off of the cylinder.
- 9.11 Remove the sliding ring (pos.5) and o-ring (pos.6) from the piston.
- 9.12 Remove the snap ring (pos.8), push the bushing (pos.9) towards the inside of the actuator and remove the gaskets (pos.10,11 and 12) away.
- 9.13 Repeat the same procedure as 9.12 for upper cover bushing.

Replacement:

- 9.14 Clean the actuator parts with a mild detergent suitable for grease removal using a brush, then dry with a cloth and compressed air.
- 9.15 Apply grease on the rough parts of back cylinder. Do not apply grease on the machined surfaces.
- 9.16 Apply grease to the o-ring and install them on the bushings. Insert and fix the bushings into the cover and cylinder.
- 9.17 Fill the grease reservoir along the outer rim of the piston.

<p>Important</p> 	<p>Apply grease to the gaskets prior installation.</p>
---	---

- 9.18 Install new gaskets kit.
- 9.19 Apply grease to the inside surface of the cylinder.
- 9.20 Install the sliding ring on the piston.
- 9.21 Install the o-ring on the piston and remove the excess grease.
- 9.22 Insert the piston into the actuator cylinder. Take care of the mounting direction.
- 9.23 Mount the upper cover on the actuator, torque the screws to the values indicated on the table below.
- 9.24 Locking the screw (pos.21/22) to the internal screwed shaft (pos.15) to the previous position marked with the pen.
- 9.25 Install the spring (pos.17) and the spring register (pos.18).
- 9.26 Install the protection cylinder (pos.28) and the cover (pos.30), tighten the nuts (pos.32).
- 9.27 Test the piston movement using an air gun.
- 9.28 Plumb all pneumatic connections and check for air leaks at 1 bar (0,1 MPa) air supply pressure. If there are no leaks, repeat the test at 7 bar (0,7 MPa).
- 9.29 Clean the excess grease from the shaft.

SC/V	Torque [Nm]
200	14 (10,3 lbf-ft)
320	20 (14,7 lbf-ft)

ANNEX C_SC/V200-320 RV: Stem Retr. + Casting Cyl.

GASKETS REPLACEMENT

SC/V 200-320 RV: Stem Retracted + Casting Cylinder

<p>Warning</p> 	<p>The following instructions must be respected:</p> <ul style="list-style-type: none"> - operations must be carried out only by qualified staff (STI operators or operators qualified by STI are recommended); - always wear protective clothing, gloves, and eyewear to prevent personal injury. Check with your process or safety engineer for any additional measures that must be taken to protect against process media.
---	--

During the gaskets replacement:

- take care to not damage gaskets grooves during maintenance;
- use only the grease type shown in the enclosed table.

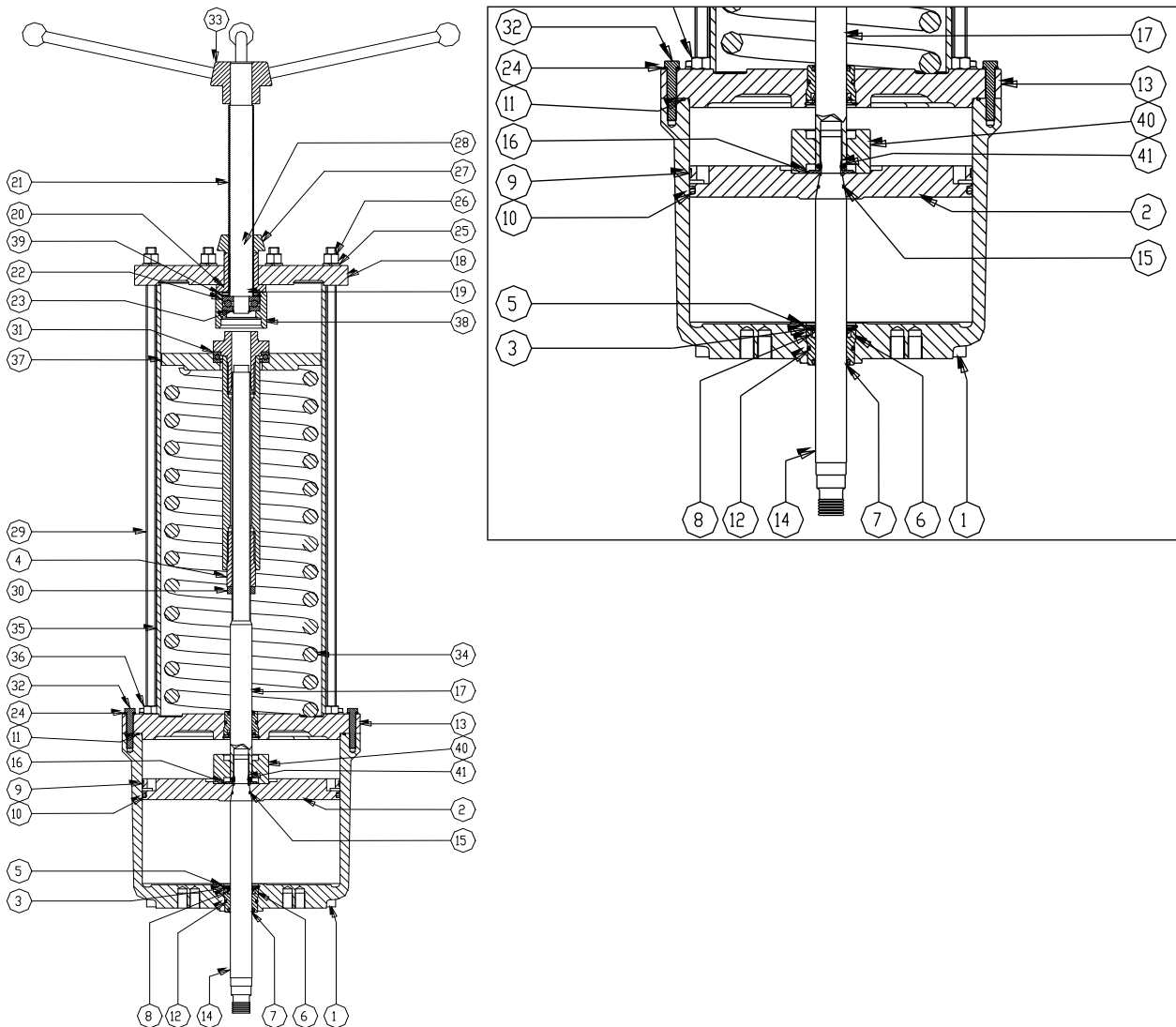

Disassembling:

- 9.1 Disconnect the actuator from the air supply and ensure the actuator is not pressurized.
- 9.2 Disconnect the actuator stem from the valve stem
- 9.3 Remove the manual override handwheel (pos.33) and disassemble the spring protection upper cover (pos.18) by unscrewing the nuts (pos.26) and removing all the accessories/fittings where needed.
- 9.4 Remove the spring protection cylinder (pos.35).
- 9.5 Mark with a pen the internal screwed shaft (pos.31) position with the screw (pos.17).
- 9.6 Prevent the shaft (pos.31) from rotating while removing the spring preloader (pos.17).
- 9.7 Remove the spring register plate (pos.37) and spring (pos. 34).
- 9.8 Remove the upper cover of the actuator (pos.13) by removing the screw (pos.32)
- 9.9 Pull the shaft (pos.14) and the piston (pos.2) from the cylinder (pos.1).
- 9.10 Take the o-ring (pos. 11) off of the cylinder
- 9.11 Remove sliding ring (pos.9) and o-ring (pos.10) from the piston.
- 9.12 Remove the snap ring (pos.5). Push the bushing (pos.6) towards the inside of the actuator cylinder and remove the gaskets (pos.8,12 and 7).
- 9.13 Repeat the same procedure as 9.11 for the upper cover (pos.13) bushing.

Replacement:

- 9.14 Clean the actuator parts with a mild detergent suitable for grease removal using a brush, then dry with a cloth and compressed air.
- 9.15 Apply grease on the rough parts of back cylinder. Do not apply grease on the machined surfaces.
- 9.16 Apply grease to the o-ring and install them on the bushings. Insert and fix the bushings into the cover and cylinder.
- 9.17 Fill the grease reservoir along the outer rim of the piston.

<p>Important</p> 	<p>Apply grease to the gaskets prior installation.</p>
---	---

- 9.18 Install new gaskets kit.
- 9.19 Apply grease to the inside surface of the cylinder.
- 9.20 Install the sliding ring on the piston.
- 9.21 Install the o-ring on the piston and remove the excess grease.
- 9.22 Insert the piston into the actuator cylinder. Take care of the mounting direction.
- 9.23 Install the upper cover on the actuator, torque the screws to the values indicated on the table below.
- 9.24 Locking the screw (pos.17) screw the internal screwed shaft (pos.31) to previous position marked with the pen.
- 9.25 Install the spring (pos.34) end the spring register (pos.37).
- 9.26 Mount the protection cylinder (pos.35) and the cover (pos.18), tighten the nuts (pos.26) and install the manual override hand wheel (pos.33).
- 9.27 Test the piston movement using an air gun.
- 9.28 Plumb all pneumatic connections and check for air leaks at 1 bar (0,1 MPa) air supply pressure. If there are no leaks, repeat the test at 7 bar (0,7 MPa).
- 9.29 Clean the excess grease from the shaft.

SC/V	Torque [Nm]
200	14 (10,3 lbf-ft)
320	20 (14,7 lbf-ft)

ANNEX D_SC/V300-400-500-520: Stem Ext. + No Casting Cyl.

GASKETS REPLACEMENT

SC/V 300-400-500-520: Stem Extended + No Casting Cylinder

<p>Warning</p> 	<p>The following instructions must be respected:</p> <ul style="list-style-type: none"> - operations must be carried out only by qualified staff (STI operators or operators qualified by STI are recommended); - always wear protective clothing, gloves, and eyewear to prevent personal injury. Check with your process or safety engineer for any additional measures that must be taken to protect against process media.
---	--

During the gaskets replacement:

- take care to not damage gaskets grooves during maintenance;
- use only the grease type shown in the enclosed table.

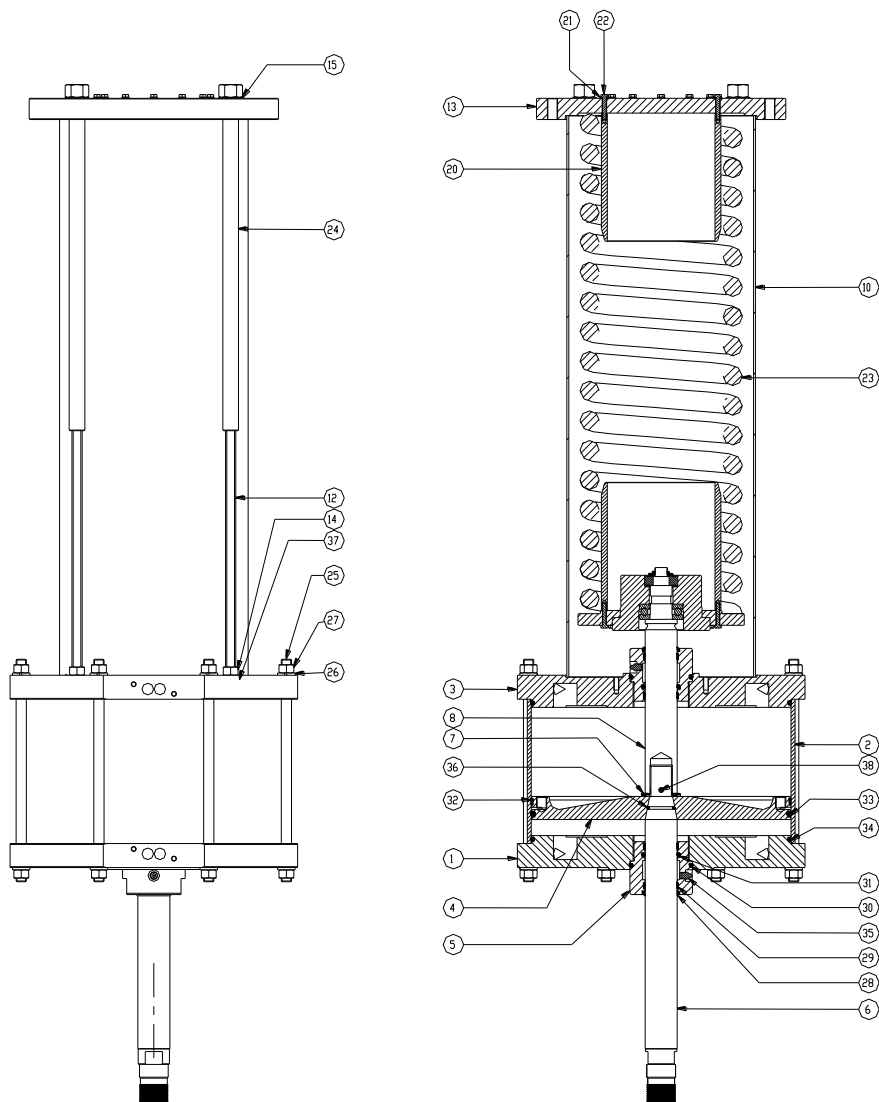

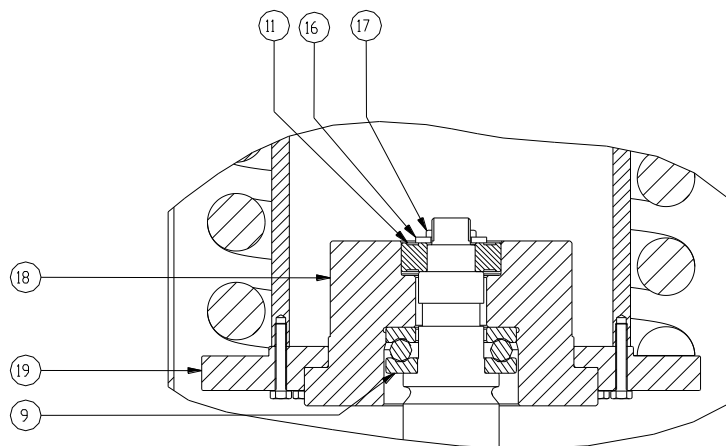

Disassembling:

- 9.1 Disconnect the actuator from the air supply and ensure the actuator is not pressurized.
- 9.2 Disconnect the actuator stem from the valve stem
- 9.3 Disassemble the spring protection upper cover (pos.13) marking the tie rod position, unscrewing the tie rods and removing all the accessories / fittings where needed.

<p>Warning</p> 	<p>Pay attention at the spring action.</p>
--	---

- 9.4 Remove the spring protection cylinder (pos.10)
- 9.5 Remove the spring (pos.23)
- 9.6 Prevent the shaft (pos.16) from rotating while removing the ring nut (pos.17).
- 9.7 Remove the spring register (pos.11/16/18/19) and the bearing (pos.9).
- 9.8 Remove the upper cover (pos.3) removing the nuts (pos.25/27)
- 9.9 Pull the shaft (pos.6) and the piston (pos.4) out off the cylinder (pos.2).
- 9.10 Remove the o-ring (pos.34) from the upper cover
- 9.11 Remove the sliding ring (pos.32) and o-ring (pos.33) from the piston.
- 9.12 Remove the bushing (pos.5) and gaskets (pos.28/29/30/31).
- 9.13 Repeat the same procedure as 9.12 for upper cover bushing.

Replacement:

- 9.14 Clean the actuator parts with a mild detergent suitable for grease removal using a brush, then dry with a cloth and compressed air.
- 9.15 Apply grease on the rough parts of back cylinder.
- 9.16 Apply grease to the o-ring and install them on the bushings. Insert and fix the bushings into the cover and cylinder.
- 9.17 Fill the grease reservoir along the outer rim of the piston.

<p>Important</p> 	<p>Apply grease to the gaskets prior installation.</p>
---	---

- 9.18 Install new gaskets kit.
- 9.19 Apply grease to the inside surface of the cylinder.
- 9.20 Install the sliding ring on the piston.

- 9.21 Install the o-ring on the piston and remove the excess grease.
- 9.22 Assemble the piston into the cylinder
- 9.23 Install the upper cover of the actuator and torque the nuts to the value indicated in the table below
- 9.24 Introduce grease into the bushing chamber using relevant lubricator.
- 9.25 Install the spring register (pos.11/16/18), the bushing (pos.16) and tighten the ring nut (pos.17).
- 9.26 Install the spring (pos.23).
- 9.27 Install the protection cylinder (pos.10) and the cover (pos.13), tighten the nuts to the tie rods.
- 9.28 Test the piston movement using an air gun.
- 9.29 Arrange all pneumatic connections and check possible air losses at 1 bar (0,1 MPa) air supply pressure. If there are no losses, repeat the test at 7 bar (0,7 MPa) air supply pressure.
- 9.30 Clean the excess grease from the shaft.

SC/V	Torque [Nm]
300	70 (51,6 lbf-ft)
400	70 (51,6 lbf-ft)
500	70 (51,6 lbf-ft)
520	70 (51,6 lbf-ft)

ANNEX E_SC/V300-400-500-520: Stem Retr. + No Casting Cyl.

GASKETS REPLACEMENT

SC/V 300-400-500-520: Stem Retracted + No Casting Cylinder

<p>Warning</p> 	<p>The following instructions must be respected:</p> <ul style="list-style-type: none"> - operations must be carried out only by qualified staff (STI operators or operators qualified by STI are recommended); - always wear protective clothing, gloves, and eyewear to prevent personal injury. Check with your process or safety engineer for any additional measures that must be taken to protect against process media.
---	--

During the gaskets replacement:

- take care to not damage gaskets grooves during maintenance;
- use only the grease type shown in the enclosed table.

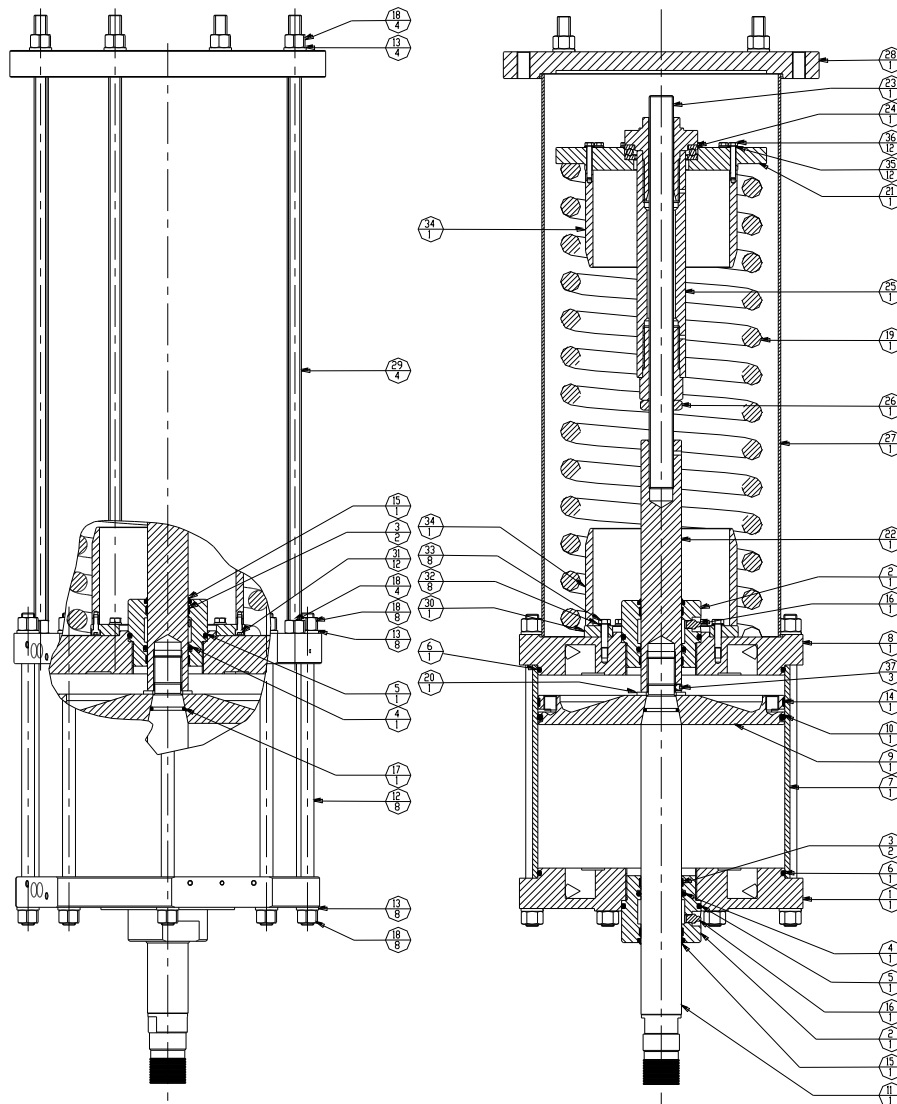

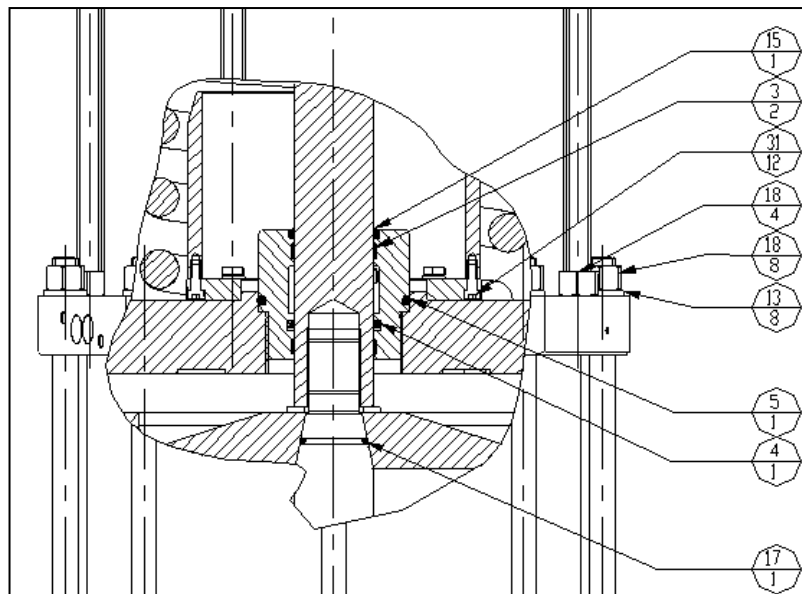

Disassembling:

- 9.1 Disconnect the actuator from the air supply and ensure the actuator is not pressurized.
- 9.2 Disconnect the actuator stem from the valve stem.
- 9.3 Disassemble the spring protection upper cover (pos.28) unscrewing the nuts (pos.18) and removing all the accessories/fittings where needed.
- 9.4 Remove the spring protection cylinder (pos.27).
- 9.5 Mark with a pen the spring preloaded (pos.25) position with the screwed shaft (pos.23).
- 9.6 Prevent the crewed shaft (pos.23) from rotating while removing the spring preloaded (pos.25).
- 9.7 Remove the spring register (pos.21) and the spring (pos.19).
- 9.8 Remove the upper cover (pos.8) removing the nuts (pos.18).
- 9.9 Pull the shaft (pos.11) and the piston (pos.9) out from the cylinder (pos.7).
- 9.10 Remove the o-ring (pos. 6) from the upper cover.
- 9.11 Remove the sliding ring (pos.14) and o-ring (pos.10) from the piston.
- 9.12 Remove the bushing (pos.2) and gaskets (pos.3,4,5 and 15).
- 9.13 Repeat the same procedure as 9.12 for the upper cover bushing.

Replacement:

- 9.14 Clean the actuator parts with a mild detergent suitable for grease removal using a brush, then dry with a cloth and compressed air.
- 9.15 Apply grease on the rough parts of back cylinder.
- 9.16 Apply grease to the o-ring and install them on the bushings. Insert and fix the bushings into the cover and cylinder.
- 9.17 Fill the grease reservoir along the outer rim of the piston.

<p>Important</p> 	<p>Apply grease to the gaskets prior installation.</p>
---	---

- 9.18 Install new gaskets kit.
- 9.19 Apply grease to the inside surface of the cylinder.
- 9.20 Install the sliding ring on the piston.
- 9.21 Install the o-ring on the piston and remove the excess grease.
- 9.22 Assemble the piston into the cylinder.
- 9.23 Install the upper cover of the actuator and torque the nuts to the value indicated in the table below.
- 9.24 Introduce grease into the bushing chamber using relevant lubricator.

- 9.25 Prevent the screwed shaft (pos.23) from rotating while install the spring preloaded (pos.25) to previous position marked with the pen.
- 9.26 Mount the spring (pos.19) end the spring register (pos.21).
- 9.27 Install the protection cylinder (pos.27) and the cover (pos.28), tighten the nuts (pos.18).
- 9.28 Test the piston movement using an air gun.
- 9.29 Arrange all pneumatic connections and check possible air losses at 1 bar (0,1 MPa) air supply pressure. If there are no losses, repeat the test at 7 bar (0,7 MPa) air supply pressure.
- 9.30 Clean the excess grease from the shaft.

SC/V	Torque [Nm]
300	70 (51,6 lbf-ft)
400	70 (51,6 lbf-ft)
500	70 (51,6 lbf-ft)
520	70 (51,6 lbf-ft)