

Quarter turn hydraulic actuator RTQH Series Double acting version type RTQH

INSTRUCTION MANUAL 5500

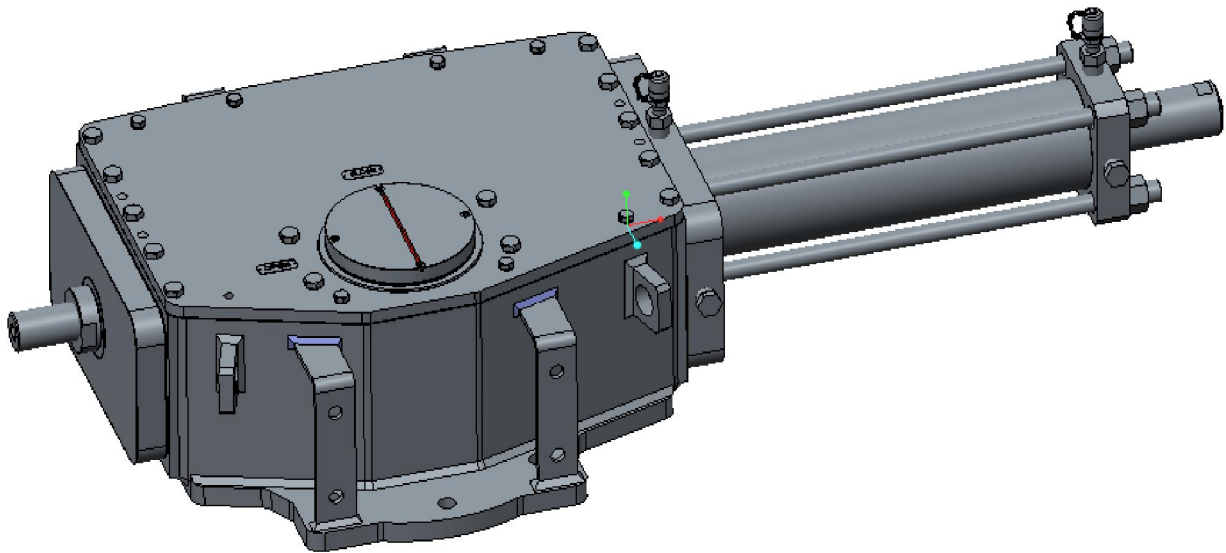

*Engineering
GREAT Solutions*

Date	Revision	Description	Compiled	Approved
<i>01/07/2020</i>	<i>5</i>	<i>Revised Nameplate (Section 4)</i>	<i>G. Alfieri</i>	<i>A. Negri</i>
<i>08/02/2018</i>	<i>4</i>	<i>Revised § 5.1</i>	<i>M. Bozzarelli</i>	<i>F. Tondolo</i>
<i>04/12/2017</i>	<i>3</i>	<i>Revised §1.6 / added §7.3</i>	<i>M. Bozzarelli</i>	<i>F. Tondolo</i>
<i>15/02/2016</i>	<i>2</i>	<i>Revision</i>	<i>M. Bozzarelli</i>	<i>D. Lamoure</i>
<i>02/10/2015</i>	<i>1</i>	<i>Revision</i>	<i>M. Bozzarelli</i>	<i>D. Lamoure</i>
<i>30/10/2013</i>	<i>0</i>	<i>Issue</i>	<i>G. Alfieri</i>	<i>D. Lamoure</i>

STI S.r.l. has taken every care in collecting and verifying the documentation contained in this Instruction Manual. The information herein contained are reserved property of STI S.r.l.

INDEX

1	GENERAL INFORMATION.....	1
1.1	GENERAL WARNINGS.....	1
1.2	GENERALITIES	1
1.3	MANUFACTURER	1
1.4	TERMS AND CONDITIONS	1
1.5	MANUFACTURER’S LIABILITY.....	1
1.6	APPLICABLE STANDARDS AND DIRECTIVES	2
1.7	SYMBOLOLOGY USED.....	2
2	DEVICE DESCRIPTION	3
2.1	GENERAL DESCRIPTION	3
2.2	IDENTIFICATION OF THE MAIN PARTS.....	3
2.3	ACTUATOR CODING DESCRIPTION.....	4
3	TECHNICAL DATA	5
4	NAMEPLATE	5
5	INSTALLATION.....	6
5.1	TRANSPORT.....	6
5.2	RECEPTION.....	7
5.3	STORAGE	7
5.4	REQUIREMENTS OF STABILITY	7
5.5	INTERFACE DOCUMENT AND DIMENSIONAL DRAWING.....	7
5.6	INSTALLATION	8
5.7	DISASSEMBLING	11
6	OPERATION AND USE.....	12
6.1	OPERATION DESCRIPTION.....	12
6.2	INTENDED USE	12
6.3	REASONABLY FORESEEABLE MISUSE	13
6.4	OPERATING LIMITS	13
6.5	RESIDUAL RISKS.....	13
7	INSTRUCTIONS FOR THE OPERATOR.....	14
7.1	START UP	14
7.2	STROKE ADJUSTMENT	15
7.3	MANUAL OVERRIDE	16
8	MAINTENANCE.....	17
8.1	PERIODIC INSPECTIONS.....	17
8.2	SPECIAL MAINTENANCE	18
8.3	REPAIRS	22
8.4	REASSEMBLING	22
8.5	MECHANISM LUBRICATION	23
8.6	HYDRAULIC FLUID	23
9	TROUBLESHOOTING.....	24
10	PARTS LIST GENERAL ASSEMBLY	24
10.1	SCOTCH YOKE MECHANISM.....	25
10.2	DOUBLE ACTING HYDRAULIC CYLINDER	26
10.3	STOP PROTECTION ASSEMBLY FOR CYLINDER	27
10.4	STOPPER ASSEMBLY FOR HOUSING SIDE WALL.....	28

11	SPARE PARTS.....	28
12	DECOMMISSIONING.....	29
13	DECLARATION OF INCORPORATION	30

1 GENERAL INFORMATION

1.1 General Warnings

Important 	<p>This Instruction Manual is an integral part of the machine, it should be carefully read before carrying out any operation and it should be kept for future references.</p> <p>This Instruction Manual covers the RTQH actuators in the base version without any accessories and/or control panel.</p> <p>In case accessories and/or control panel are foreseen mounted on the actuator an additional Section to this Instruction Manual will be attached to the specific actuator.</p> <p>This Instruction Manual is realized in accordance with the Directive 2006/42/CE.</p>
---	---

1.2 Generalities

STI S.r.l. actuators are conceived, manufactured and controlled according to the Quality Control System in compliance with EN ISO 9001 International Standard.

1.3 Manufacturer

With respect to Machinery Directive 2006/42/EC the Manufacturer of the described RTQH actuator series, is **STI S.r.l.** as specified on the machinery label.

STI S.r.l. Via Dei Caravaggi 15
24040 Levate (BG) Italy
Tel. +39 035 2928.2
Fax +39 035 2928.247
imisti.sales@imi-critical.com

1.4 Terms and conditions

STI S.r.l. guarantees each single product to be free from defects and to conform to current goods specifications. The warranty period is one year from the date of installation by the first user, or eighteen months from the date of shipment to the first user, whichever occurs first.

The warranty does not cover special products or components not covered by warranty in their turn by subcontractors. No warranty is given for products which have been subject to improper storage, improper installation, misuse, or corrosion, or which have been modified or repaired by unauthorised personnel. Repair work due to improper use will be charged at standard rates.

1.5 Manufacturer's Liability

STI S.r.l. declines all liability in the event of:

- use of the actuator in contravention of local safety at work legislation
- incorrect installation, disregard or incorrect application of the instructions provided on the actuator nameplate and in this manual
- modifications without STI's authorisation
- work done on the unit by unqualified or unsuitable persons.

1.6 Applicable Standards and Directives

1.6.1 General Standards

- EN ISO 12100:2010: Safety of machinery - General principles for design.
Risk assessment and risk reduction.
- IEC 61508-1/7 (Ed. 2010)
- IEC 61511-1 (Ed. 2016)

1.6.2 European Directives (mandatory only for installations in EU Countries)

- 2006/42/EC Machinery Directive.
- 2014/68/EU Pressure Equipments Directive (PED)
- 2014/35/EU Directive for Low Voltage Equipment (LV)**
- 2014/30/EU Directive relating to the Electromagnetic Compatibility (EMC)**
- 2014/34/EU Directive concerning equipment for use in potentially explosive atmospheres (ATEX)

** Applicable only when electrical control panel is supplied integrate with the actuator

1.7 Symbology Used

1.7.1 Signs of warning

Be careful where these symbols are shown, they indicate a potentially hazardous situation and they warn that if the steps are not properly performed, MAY RESULT CAUSING serious injury, death or long-term risks to the health of exposed persons.



GENERAL DANGER



DANGER POWER SUPPLY



CRUSHING HAZARD

1.7.2 Signs of obligation



General obligation (with the possible supplementary signboard)



Must wear protective clothing.



Obligation to wear protective footwear.



Is required to wear a helmet.



Is required to protect the eyes.



Obligation to protect your hearing.

2 DEVICE DESCRIPTION

2.1 General Description

RTQH double acting hydraulic actuators, are suitable for the operation of quarter turn valves (ball valves, butterfly valves, plug valves) for ON-OFF and modulating heavy-duty service

The actuator is made up of a weatherproof scotch yoke mechanism transforming the linear movement of the hydraulic cylinder (on closing or opening) into the rotary movement, which is necessary for valve operation. The travel stroke of the yoke is adjustable between -4 deg / +4 deg at both ends by means of the external mechanical stops arranged into the side-wall of the mechanism body and into the end flange of the hydraulic cylinder.

Scotch yoke mechanism centerbody cover is machined to provide the assembly pattern for any required accessories (i.e. positioner, signaling limit switches, position transducer, etc.) by means of proper matching units. The above mentioned accessories are operated by the actuator drive sleeve.

Actuator centerbody bottom wall is machined with threaded holes to allow actuator mounting on top of valve top-work either directly or, when required, with the interposition of an adaptor flange or a mounting bracket.

2.2 Identification of the Main Parts

The RTQH actuator is composed by the following main parts:

- 1) Scotch yoke mechanism.
- 2) Hydraulic cylinder.
- 3) Stop settings screw kit.
- 4) Stopper screw assembly.
- 5) Seal Kit.
- 6) Position Indicator.

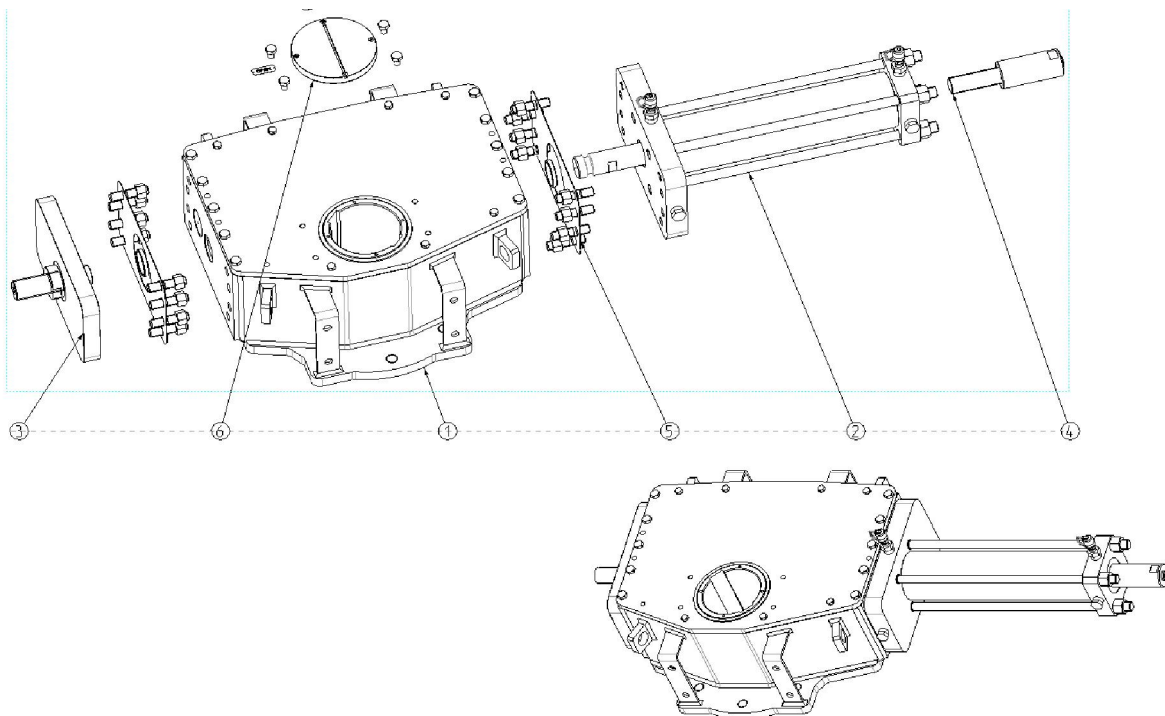
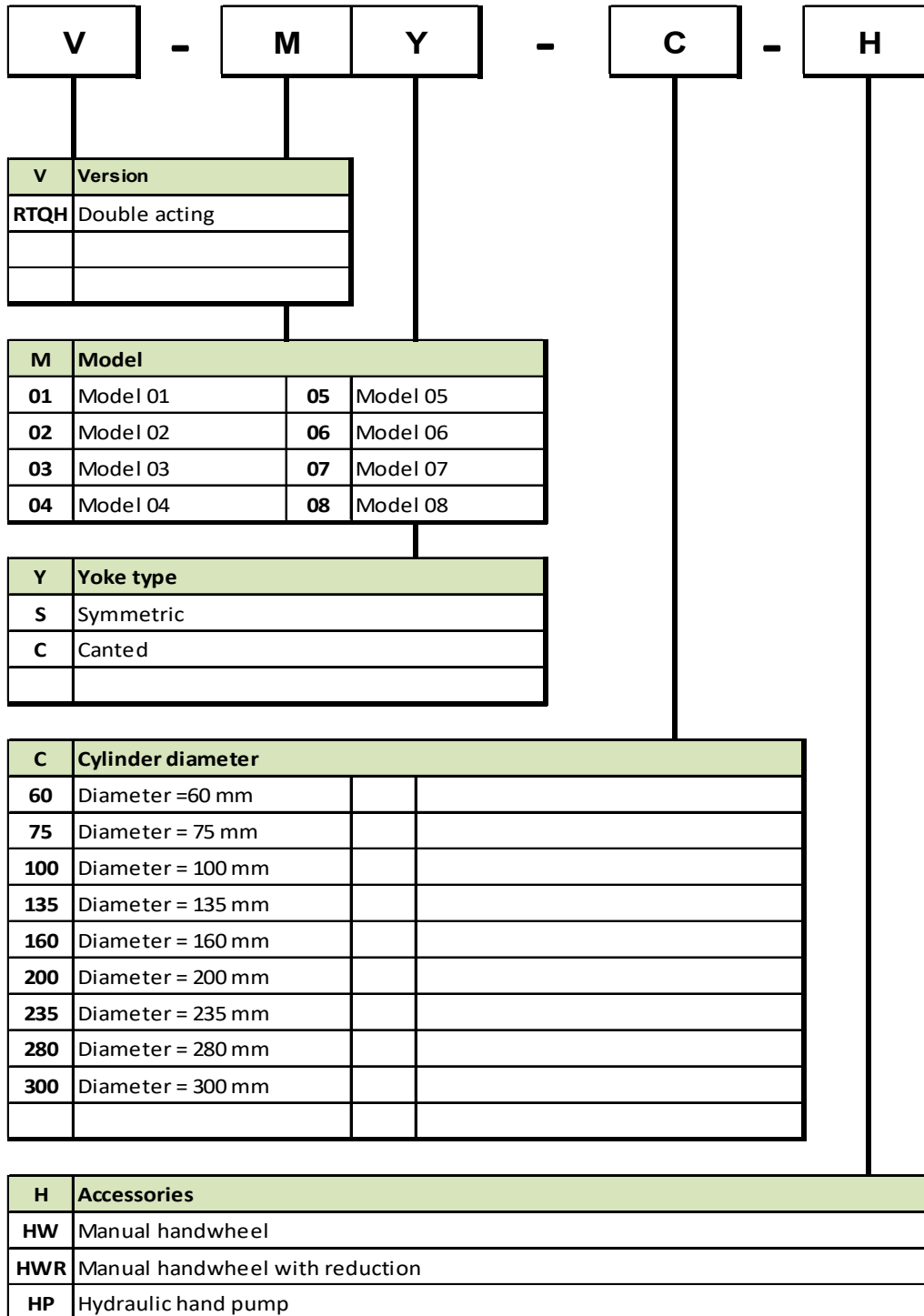

Fig. 1: Main parts for RTQH actuator series

2.3 Actuator coding description





3 TECHNICAL DATA

DATA	
Supply medium	Hydraulic fluid (see Section 8.6)
Operating temperature ranges	General applications (outside EU Countries): Standard: -30°C +100°C Optional: -60°C +100°C (*) PED applications (within EU Countries): Standard: -20°C +100°C Optional: -50°C +100°C (*) (*) for SIL applications T° amb. min ≥ -40°C
Cylinder design pressures	103, 207 or 345 bar
Operating pressure range	Data are available on actuator nameplate depending on customer requirements and specifications
Max operating torque (MOT)	RTQH 01 models: up to 12.000 Nm RTQH 02 models: up to 22.000 Nm RTQH 03 models: up to 40.000 Nm RTQH 04 models: up to 70.000 Nm RTQH 05 models: up to 125.000 Nm RTQH 06 models: up to 220.000 Nm RTQH 07 models: up to 400.000 Nm RTQH 08 models: up to 600.000 Nm
Design life	30 years
Applications	On-Off Modulating service (on request)

The nameplate fastened on the actuator contains the main actuator operating condition. It is forbidden to modify the information and the marks without previous written authorization by STI S.r.l.

4 NAMEPLATE

 STI s.r.l. Via Dei Caravaggi 15 - 24040 LEVATE (BG)-ITALY www.imi-critical.com - FAX +39 035 2928247			
 II 2 GD		Ref. INERIS <input type="text"/>	
Ex h II <input type="checkbox"/> T4 Gb / Ex h III C T135°C Db		Certificate IECEX INE 19.0024	
Order	<input type="text"/>	Serial N°	<input type="text"/>
Model	<input type="text"/>	Year	<input type="text"/>
Rated Torque	<input type="text"/> Nm	Max. allowable Pressure	<input type="text"/> bar
Pressure Range	min <input type="text"/> / max <input type="text"/> bar	Fluid	<input type="text"/>
Temp. Range	min <input type="text"/> / max <input type="text"/> °C	Valve TAG	<input type="text"/>
Degree of Protection IP66/67N according to IEC/EN 60529			

5 INSTALLATION

<p>Important</p> 	<p>Not performing the following procedures will invalidate the product guarantee.</p>
---	---

5.1 Transport

<p>Warning</p> 	<p>The lifting and handling must be made by qualified staff and in compliance with the laws and provisions in force.</p> <p>Lift the actuator as shown in Figure 2 taking care that the maximum opening angle between the chains remains below 90°.</p> <p>The lifting points are appropriate for the lifting of the actuator alone and not for the valve + actuator assembly.</p> <p>Avoid that during the handling, the actuator passes above the staff.</p> <p>The actuator should be handled with appropriate lifting means considering the mass of actuator. The mass is printed on the label of the actuator.</p> <p>The mass is also reported on the delivery bill and on overall-dimensions drawings furnished with the documents accompanying the actuator.</p> <p>In case the information regarding the weight is missing consult www.stiactuation.com for base actuators or ask this information at info@stistrumentazione.com</p>
---	---

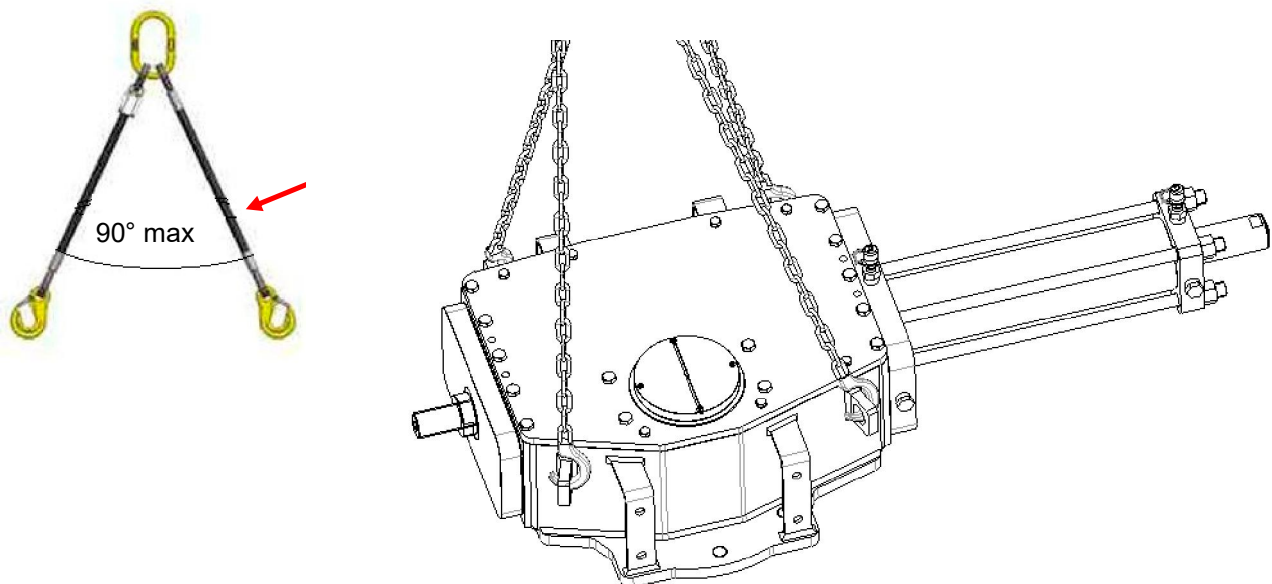

Fig. 2 – Lifting points for RTQH actuator series

5.2 Reception

- Check that the model, the serial number of the actuator and the technical data reported on the identification plate correspond with those of order confirmation (Sect. 4).
- Check that the actuator is equipped with the fittings as provided for by order confirmation.
- Check that the actuator was not damaged during transportation: if necessary renovate the painting according to the specification reported on the order confirmation.
- If the actuator is received already assembled with the valve, its settings have already been made at the factory.
- If the actuator is delivered separately from the valve, it is necessary to check, and, if required, to adjust, the settings of the mechanical stops (Sect. 7.2).

5.3 Storage

All the actuators RTQH leave the factory in perfect condition. Performances of each unit are guaranteed by individual test and data reported on a specific test certificate issued for each unit.

In order to maintain these characteristics until the RTQH actuator is installed on site, proper attention must be observed for preservation during the storage period.

If the actuator needs storage, before installation follow these steps:

- Place it on a wood surface pallet or on metallic support, so that they are not in direct contact with the ground, in order not to deteriorate the area of valve coupling, later it must be packed with appropriate covering.
- Make sure that plastic plugs are present on the hydraulic and electrical connections (if present).
- Check that the limit switch box (if any) is properly closed.
-

If the storage is long-term or outdoor:

- Keep the actuator protected from direct weather conditions.
- Replace plastic plugs of hydraulic and electrical connections (if any) with metal plugs that guarantee perfect tightness.
- Coat with oil, grease or protection disc, the valve coupling area.
- Periodically operate the actuator (Sect.6).

5.4 Requirements of Stability

- Conditions in which the machinery meets the requirement of stability during use, transportation, assembly, dismantling when out of service, testing or foreseeable breakdowns, are shown in Fig.2.
- The actuator must be put, with extreme caution, in a right position on a plane surface and with adapted capacity to the load to support.
- Do not use actuator eye bolts lifting of valve-actuator package.
- Concerning the requirement of stability during installation and disassembling it 's possible to refer to the next chapters 5.6 and 5.7.

5.5 Interface document and dimensional drawing

- Hydraulic diagrams, wiring diagrams and dimensional drawing are furnished with document accompanying the actuator.

5.6 Installation

Warning	
	<p>Before proceeding with any Installation the following instructions must be respected:</p> <ul style="list-style-type: none"> - Always wear protective clothing, gloves, and eyewear to prevent personal injury. - Use the lifting point foreseen on the actuator to move the actuator: if different instructions are not well specified the lifting points foreseen on the actuator must be used only to move the actuator. - Check with your process or safety engineer for any additional measures that must be taken to protect against process media.

5.6.1 Checks to be performed before installation

If the RTQH actuator is purchased separately, proceed as follows before assembling it onto the valve:

- Check that the coupling dimensions of the actuator/coupling block flange and stem meet the specified coupling dimensions.
- Prepare the necessary tools for the assembly and setting of the unit.
- Check that the outer surface of the actuator is free from dust and dirt.
- Clean the actuator flange and remove anything that might prevent a perfect adherence to the actuator/coupling block flange and joint especially all traces of grease.

5.6.2 Assembling of the actuator on the valve

The actuator can be assembled on top of the valve flange either by using the actuator-housing flange with threaded holes, or by the interposition of a proper mounting hardware. The actuator drive sleeve is generally connected to the valve stem by an insert bush or a stem extension. The assembly position of the actuator, with reference to the valve, must comply with the plant requirements (cylinder axis parallel or perpendicular to the pipeline axis).

To assemble the actuator onto the valve proceeds as follows (see Fig. 3):

- Move the valve and the actuator to their safe position (position reached in case of lack of pressure)
- If an insert bush or stem extension for the connection to the valve is supplied separately, assemble it onto the valve stem and fasten it by tightening the proper stop dowels.
- Connect a sling to the support points of the actuator and lift it: make sure the sling is suitable for the actuator weight
- Lower the actuator onto the valve in such a way that the insert bush, assembled on the valve stem, enters the actuator drive sleeve. This coupling must take place without forcing and only with the weight of the actuator.
- When the insert bush has entered the actuator drive sleeve, check the holes / pin of the valve flange meet the actuator holes and pin, otherwise rotate the mounting bracket to obtain a right assembling.

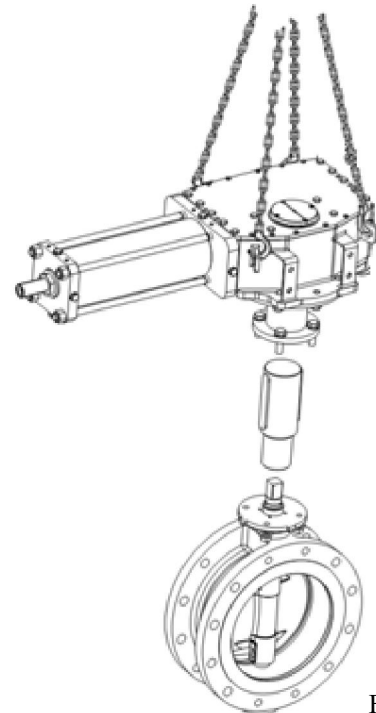

Fig.3



 Important	<p>To guarantee the correct transmission of torque from the actuator to valve stem without phenomena of slip it is important to remove any trace of oil and/or grease from the mating surfaces of valve and actuator or bracket and tighten the nuts fixing the bolts with the torque specified into the following Table 1</p>
---	--

Table 1

Threading	Tightening torque (Nm)	Threading	Tightening torque (Nm)
M8	20	M24	550
M10	40	M27	700
M12	70	M30	800
M14	110	M33	1200
M16	180	M36	1800
M20	340		

The torque values in Table 1 have been calculated considering the materials ASTM A320 grade L7/ASTM A193 grade B7 for screws or tie rods and ASTM A194 grade 4 for the nuts. Alternative bolting permitted i.e. ASTM A193 B8M (or B8M3) for tie rods and ASTM A194 Gr.8M for the nuts, provided that yield strength of screws or tie rods is over than 450 Mpa.

5.6.3 Hydraulic Connections

 Warning	<p>Check that the values of hydraulic supply available are compatible with those reported on the identification plate of the actuator.</p> <p>Use pipes and connections appropriate as for type, rating, material and dimensions.</p> <p>The connection should be made by qualified staff.</p>
---	--

- Properly deburr the ends of rigid pipes.
- Properly clean the interior of pipes sending through them plenty of the supply fluid used in the system.
- Mould and fasten the connection pipes so that no irregular strains at entries or loosening of threaded connections occur.
- Make the connections according to the operating diagram.
- Check the absence of leakages from hydraulic connections. If necessary tighten the nuts of the pipe-fittings.

5.6.4 Electrical Connections (If any)

<p>Warning</p> 	<p>Before carrying out electrical connections, switch off any power and control lines. Use components appropriate as for type, material and dimensions. The connections should be made by qualified staff.</p>
---	--

- Introduce connection cables.
- Make the connections in compliance with applicable wiring diagrams on the documentation supplied.
- Screw the cable gland.
- Replace the plastic plugs of unused entries with metal plugs.

5.6.5 Earthing connection

If the earthing connection is not guaranteed through mechanical parts where actuator is mounted, it is necessary ensure a directly earthing connection on provided point of actuator.

5.7 Disassembling

<p>Warning</p> 	<p>Before starting the disassembly operations it is mandatory to disconnect the hydraulic power and to exhaust the cylinder and any other pressure retaining component mounted on the actuator.</p> <p>Before removing the screws between actuator and valve or adaptor flange or mounting bracket, the actuator should be connected with appropriate lifting means. Lift the actuator as shown in Fig.3. The lifting points are appropriate for handling the actuator alone and <u>not for the valve + actuator assembly.</u></p> <p>During the disassembling take care that the mounting coupling block is fix on the valve stem to avoid any dangerous situation.</p>
---	---

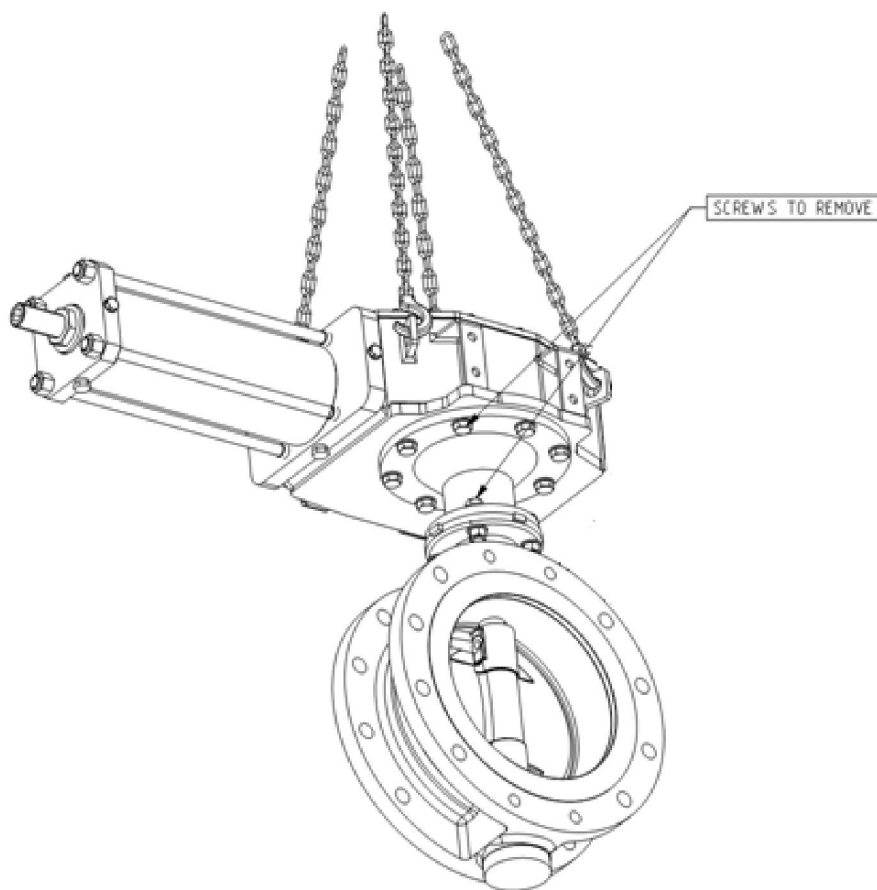

Fig. 4 – Disassembling of the actuator

6 OPERATION AND USE

6.1 Operation description

The RTQH series is hydraulic actuator designed for on-off and control service and is applicable over a wide range of pressure, temperatures and environments.

The scotch yoke mechanism converts the linear motion of hydraulic piston into valve rotation by the actuator shaft.

Depending which chamber of cylinder is pressurized, the valve either opens or closes.

The symmetric scotch yoke mechanism generates high torque at start (0° degree) and the end (90° degree) of the valve stroke, typically valve torque figure of ball valve. The canted scotch yoke mechanism generates very high torque when valve is closed, typically valve torque figure of butterfly valve.

6.2 Intended use

The machinery covered in this Instruction Manual is single acting hydraulic RTQH actuator series designed to operate a quarter turn industrial valve (ball valves, butterfly valves, plug valves, dampers,...) for ON-OFF or modulating heavy duty service.

This RTQH actuator is produced by **STI srl** [Manufacturer] and identified by a label with a product designation code. **STI srl** will not be liable for any possible damage or physical injury resulting from use in other than the designated applications or by lack of care during installation, operation, adjustment and maintenance of the machine. Such risks lie entirely with the user. Depending on the specific working conditions, additional precautions may be requested. Considering that **STI srl** has no direct control over particular applications, operation or maintenance conditions, it is the operator's responsibility to comply with all applicable safety rules. Please inform **STI srl** urgently if you face unsafe situations not described in this Instruction Manual. It is the sole responsibility of the operator to ensure that the local health and safety regulations are adhered to.

RTQH actuator is designed in accordance with the applicable International Rules and Specifications, but the following Regulations must be observed in any case:

- the general and safety regulations
- the plant specific regulations and requirements
- the proper use of personal and protective devices (glasses, clothing, gloves, etc)
- the proper use of tools, lifting and transport equipment.

<p>Warning</p> 	<p>It is severely forbidden to use the RTQH actuators series for purpose or application other than those for which it was designed and here above specified</p>
---	--

6.3 Reasonably foreseeable misuse

A short list of reasonably foreseeable misuse :

- Installation in ambient with not planned conditions: i.e. climatic conditions different from the specified conditions;
- Insert incorrect fluid into the system;
- Supply pressure out of required range;
- Lifting of the actuator with valve through eye bolts.

6.4 Operating limits

Operating conditions are described in paragraph 3, the nameplate fastened on the actuator contains the main actuator operating condition for the specified application.

<p>Warning</p> 	<p>It is severely forbidden to use the actuator under conditions other than those provided on the nameplate.</p>
---	---

6.5 Residual Risks

<p>Warning</p> 	<p>The actuator has parts under pressure. Use the due caution. Use individual protections provided for by the laws and provisions in force.</p>
---	--

- Risk due to movements of loads during load displacements, assemblage and maintenance servicing.
- Electrical risk due to an incorrect application of the instruction.
- Crushing during assemblage and maintenance servicing.
- Extreme metal temperature at high (over than 80°C) or very low values as consequence of ambient temperature as to be considered as a risk of person injury in case of contact.
- Emissions of hazardous substances where natural gas is used as motive energy.

7 Instructions for the operator

7.1 Start Up

During the start-up of the actuator, proceed as follows:

- Check that the pressure and quality of the hydraulic fluid (filtering degree,....) are as prescribed.
- Check that the feed voltage values of the electric components (solenoid valve coils, micro-switches, pressure switches, etc.) are as prescribed.
- Check that the actuator controls work properly (remote control, local control, emergency controls, etc.)
- Check that the required remote signals (valve position, air pressure, etc.) are correct.
- Check that the setting of the components of the actuator control unit (pressure regulator, pressure switches, flow control valves, etc.) meet the plant requirements.
- Check that there are not leak in the hydraulic connections. If necessary tighten the nuts of the pipe fittings.
- Remove all rust and, in accordance with the applicable painting specifications, repair paint-coat that has been damaged during transport, storage or assembly.

7.2 Stroke adjustment

<p>Important</p> 	<p>It is assumed that the following instructions are executed in the workshop using air as the power fluid. Instructions are applicable when the actuator is already installed on the valve.</p>
---	---

It is important that the mechanical stops of the actuator (and not those of the valve) stop the rotary stroke at both extreme valve positions (fully open and fully closed), except when different configuration is required by the type of the valve (i.e.: eccentric butterfly valves,...).

The setting of the open/closed valve position is performed by adjusting the setting screws foreseen into the end flange of the cylinder and on the side wall of the scotch yoke mechanism (see Fig. 5 and Fig. 6) following the instructions listed here below.

For the adjustment of the travel stop screw in the end flange of the hydraulic cylinder proceed as follows (Fig.5):

- Loosen the plug (4.4) from the travel stop protection (4.2) keeping the latter locked with a proper wrench key.
- Adjust the valve stroke screw/unscrew the travel stop screw (4.1)
- After detected the right position, tight the travel stop protection (4.2) against the cylinder end flange keeping the stopper screw (4.1) locked Screw the plug (4.4) into the travel stop protection (4.2).

For the open position adjustment on the travel stop located into the actuator centerbody side-wall proceed as follows (Fig.6):

- Loosen the nut (3.1) from the travel stop screw (3.2) keeping the latter locked with a proper wrench key.
- Adjust the valve stroke screw/unscrew the travel stop screw (3.2)
- After detected the right position, tight the nut (3.1) keeping the travel stop screw (3.2) locked.

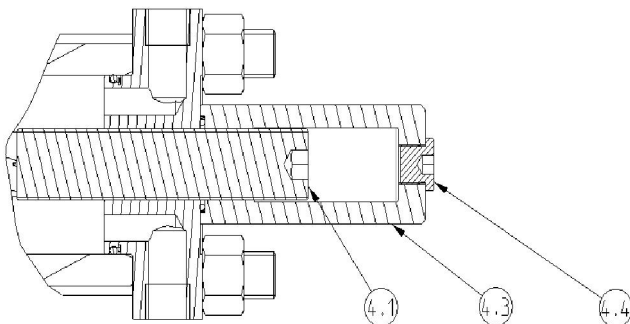

Fig. 5 – Stroke adjustment

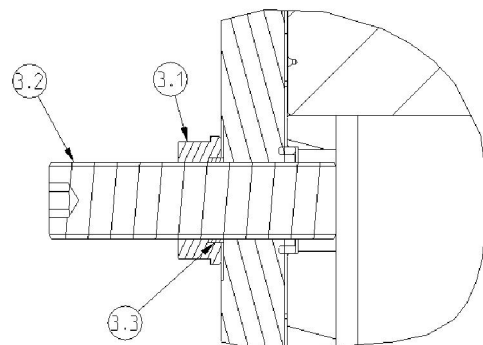



Fig. 6 – Stroke adjustment

<p>Important</p> 	<p>Operate the actuator with hydraulic supply to check that the actuator moves properly and that there are no leakages.</p>
---	--

7.3 Manual Override

When requested, a manual override to move the actuator in case of lack of hydraulic pressure is supplied as an integral part of the actuator itself.

For the double acting actuators Series RTQH the manual override is based on cylinder with hydraulic hand pump type HP.

<p>Important</p> 	<p>Position of the valve and position of the manual override in relation to the actuator availability MUST be always known.</p> <p>The following paragraph 7.3.1 provides the information to enable the operator to know the position of the manual override.</p> <p>Position of the valve is provided by the local indicator described at paragraph 2.2 item 6).</p>
---	--

7.3.1 Indication of position of the manual override type HP

For this type of Manual Override a specific **Instruction Manual 2094** is available.

By means a selector lever it is possible to select LOCAL or REMOTE operation. (see Figure 7)

When lever of the local selector is in LOCAL position, identified by a specific label fixed on device, the manual override HP is engaged, consequently the actuator cannot be operated by remote inhibiting its safety function. To restore the automatic function the selector lever must be rotated 90° clockwise towards the position identified by the label REMOTE.

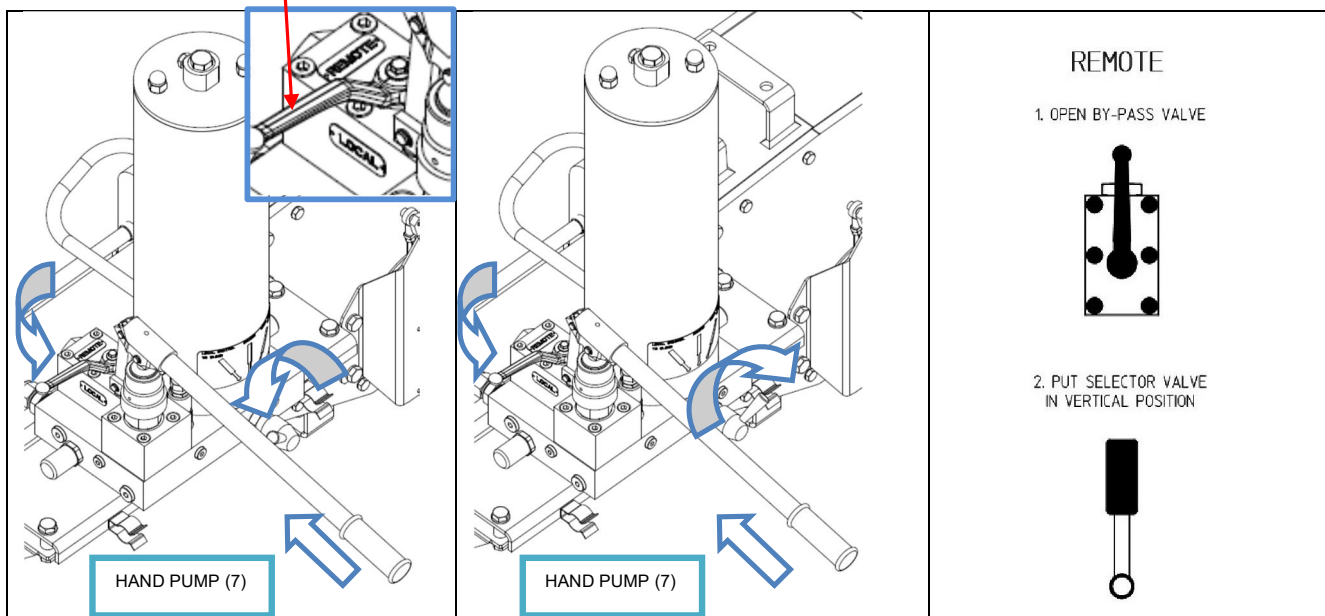



Fig. 7 – HP device

8 MAINTENANCE

8.1 Periodic Inspections

Inspect the general conditions at regular intervals: recommended frequency of inspection is one time every two years but this frequency could be changed depending on the installation and working conditions.

- Check that the actuator operates the valve correctly and with the required operating times. If the actuator operation is very infrequent, carry out a few opening and closing operations with all the existing controls (remote control, local control, emergency controls, etc.), if this is allowed by the conditions of the plant.
- Check that the signals to the remote control desk are correct.
- Check that the hydraulic supply pressure value is within the required range.
- If there is an air filter on the actuator, bleed the condense water accumulated in the cup by opening the drain cock. Disassemble the cup periodically and wash it with soap and water; disassemble the filter: if this is made up of a sintered cartridge, wash it with nitrate solvent and blow through with air. If the filter is made of cellulose, it must be replaced when clogged.
- Check that the external components of the actuator are in good conditions.
- Check all the paint-coat of the actuator. If some areas are damaged, repair the paint-coat according to the applicable specification.
- Check that there is no leak in the hydraulic connections. If necessary tighten the nuts of the pipe-fittings.

Warning 	<p>Take care that a build-up of dust or dirt on the actuator can inhibit cooling and contribute to increase surface temperature. The user should plan and provide for a periodic cleaning/maintenance program that will maintain the external surface of the actuator free from excessive layer of dust.</p>
---	---

Important 	<p>Use only STI :original spare parts. STI cannot accept responsibility for any damages that occur from using spare parts or fastening materials from other manufacturers.</p> <p>If STI products (i.e. gasket, o-ring etc) have been on store for longer periods check these for corrosion or deterioration before using these products.</p>
---	---

8.2 Special maintenance

Under normal condition the actuator don't need special maintenance. If there are leaks in the hydraulic cylinder or a malfunction in the mechanical components, or in case of scheduled preventive maintenance, the actuator must be disassembled and seals must be replaced with reference to the attached sectional drawing and adopting the following procedures.

Important 	Before performing any maintenance operations use always wear protective gloves, clothing, and eyewear when performing any maintenance operations.
---	--

Warning 	Before proceeding with any maintenance operation the following instructions must be respected: <ul style="list-style-type: none">- Disconnect any operating lines providing air pressure, electric power, or a control signal to the actuator. Be sure the actuator cannot suddenly open or close the valve- Close the hydraulic feed line and exhaust the pressure from the actuator cylinder and from the control unit, to ensure safety of maintenance staff.
---	--

8.2.1 Scotch yoke Mechanism seals replacement

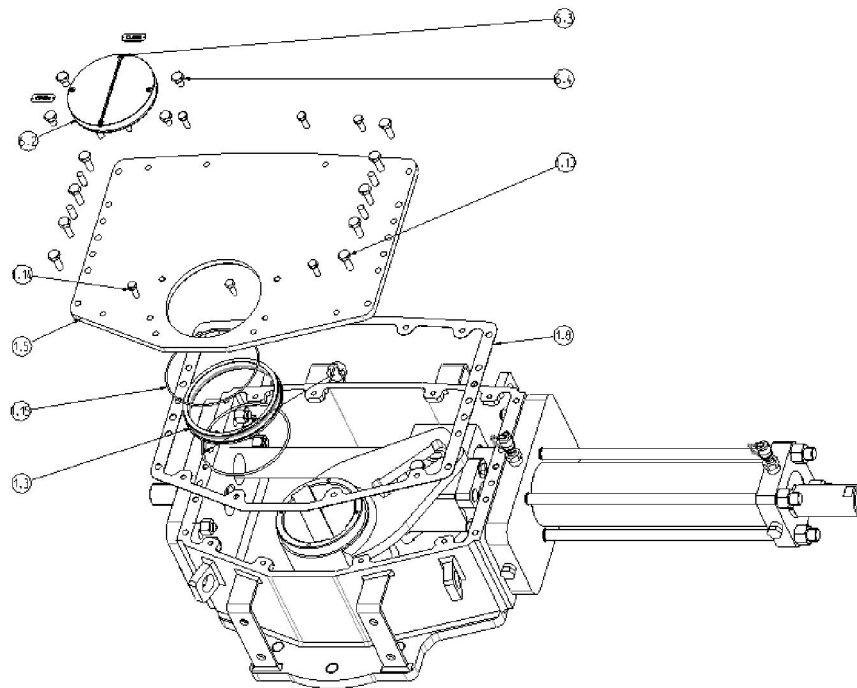

Fig. 8 – Scotch yoke mechanism seals replacement

To replace the cover gasket (1.8) under the cover (1.5), the position indicator (6.2) and relevant screws (6.3) and all the cover's screws (1.13, 1.14) must be removed.

Before replace cover gasket clean the housing and cover.

After removing the cover you may disassemble the bushing (1.3) and replace the O-ring (1.15, 1.16).

Clean the seal groove carefully and lubricate it with protective oil or grease film.

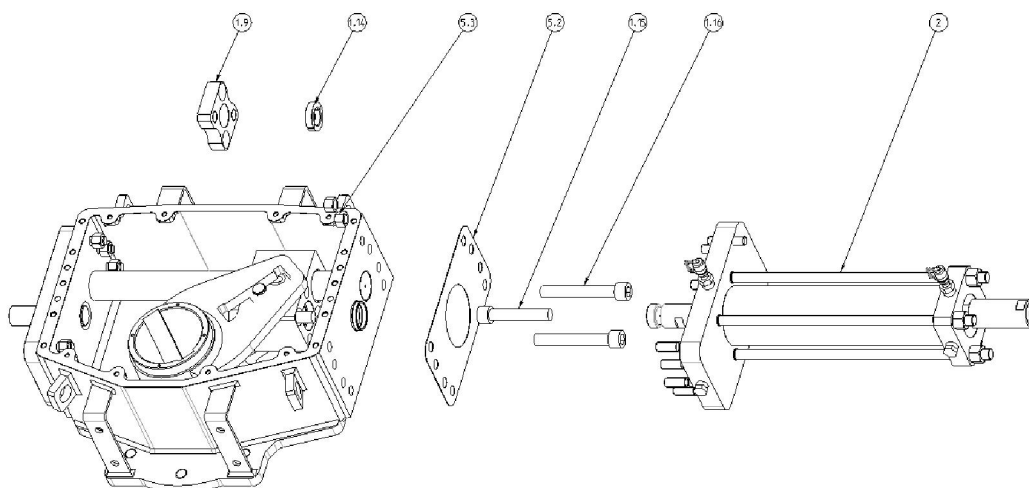
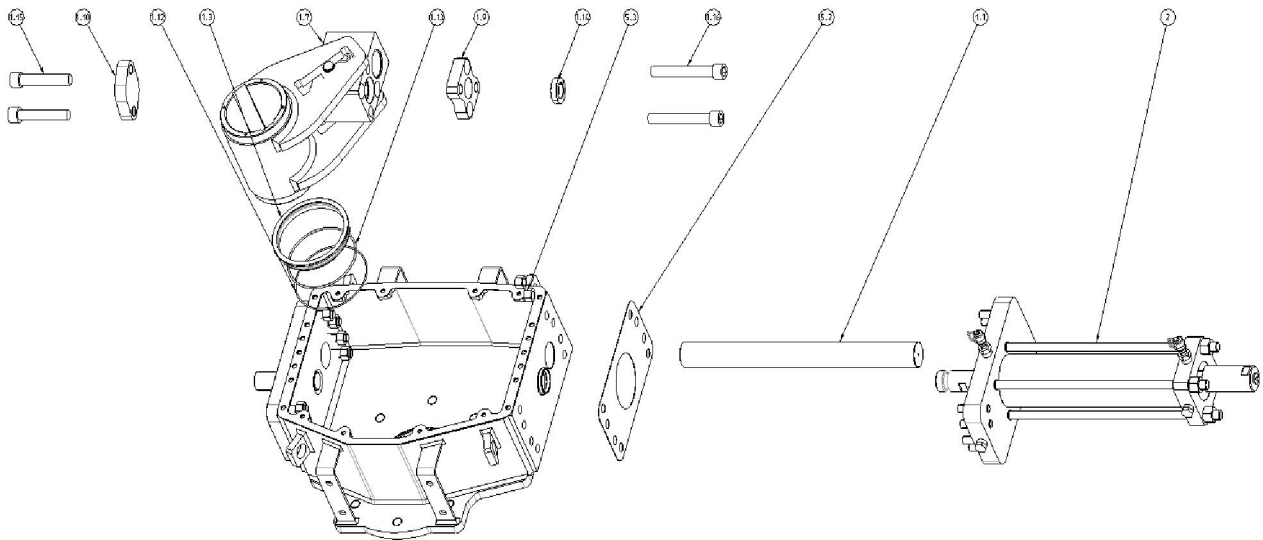

Fig. 9 – Scotch yoke mechanism seals replacement.

Once perform these actions is possible to remove the gasket between actuator housing and cylinder (2):
 Remove the screw (1.16) to disengage the guide block from spring cartridge, move the scotch yoke in central position (45°) remove the screw (1.15) to disengage the 2 off half rings (1.14) from flange (1.9), remove the

fixing nut (5.3) on the cylinder side, remove, remove the cylinder (2) and replace the gasket (5.2), before replace cylinder clean the surface of housing and cylinder head flange.



At these point is possible replace the O-ring on the bottom of the scotch yoke.

Remove the guide bar (1.1) extract the scotch yoke (1.7) and guide block (1.2) disassemble the bushing (1.3) and replace the O-ring (1.15, 1.16).

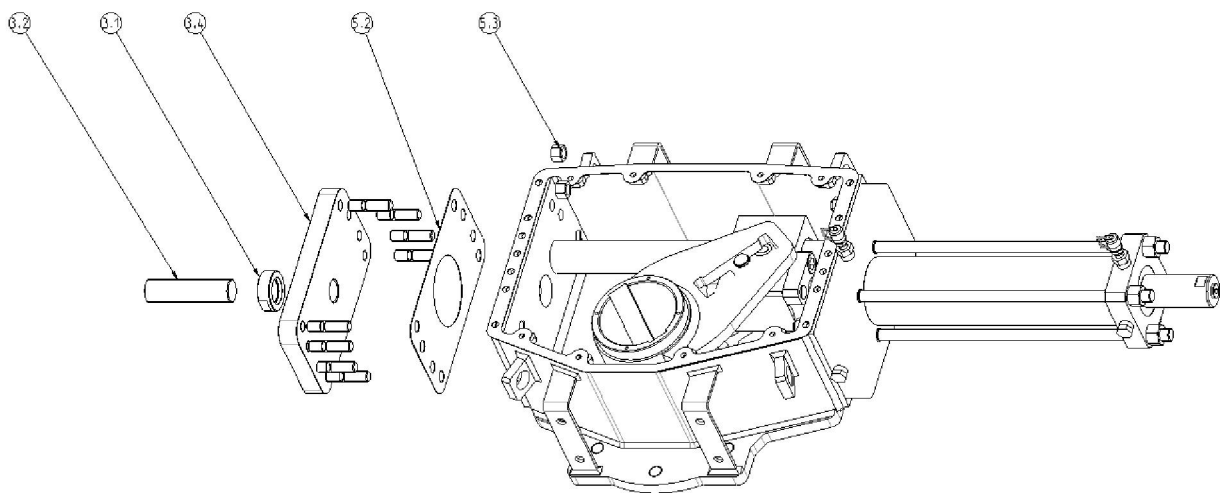

Fig. 10 – Scotch yoke mechanism seals replacement

To replace the gasket between actuator and stop settings screw kit, once the cover (1.5) has been removed, is necessary remove the fixing nut (5.3) on the side without cylinder, remove the screw, remove flange (3.4) and replace the gasket (5.2), before replace flange and kit stopper clean the surface of housing and flange (3.4).

8.2.2 Hydraulic cylinder seals replacement.

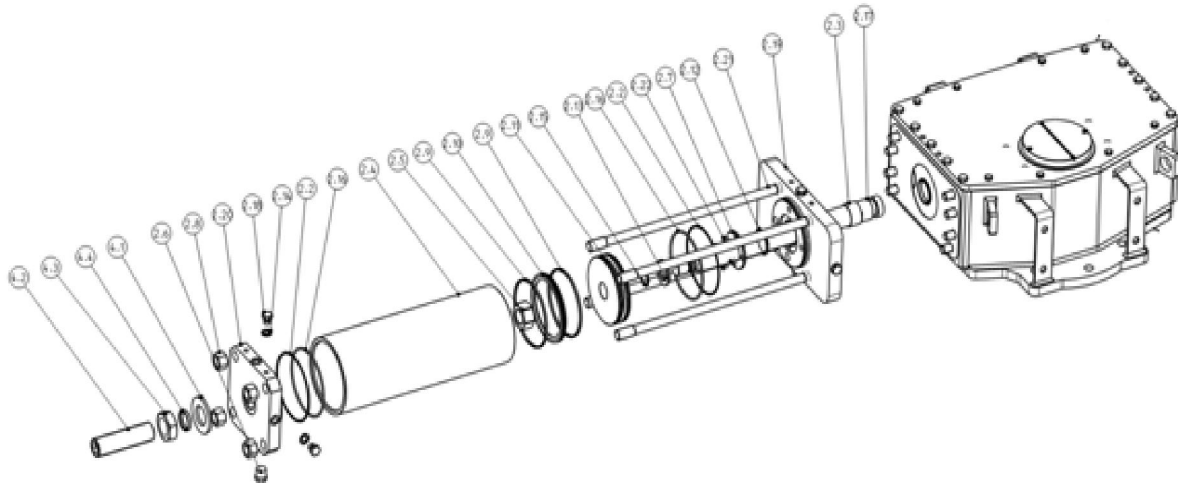

Fig. 11 – Hydraulic cylinder seals replacement

It is possible to completely disassemble the cylinder without disconnecting it from the actuator body in order to replace the seals.

Remove the nuts (2.8) from tie rods, remove the end flange (2.20) after that replace the o-ring (2.16) and back-up ring (2.2) from the seal groove.

Disassemble the cylinder tube (2.4) to replace the sliding guides (2.9) and piston seal (2.10) from the seal groove and the o-ring (2.16) and back-up ring (2.2) on the head flange (2.19).

Remove the nut (2.5) from the piston rod (2.17), remove the piston (2.11) and replace the O-ring (2.15) and back-up rings.

Unscrew the screws (2.22), disassemble the flange (2.7) and replace the piston rod Seal-ring (2.12).

Remove the nut (4.3) holding the travel stop (4.2) and the washer (4.1) and then, if necessary, replace the sealing washer (4.4).

Before re-assemble clean all seal grooves carefully and lubricate them with protective oil or grease film.

It is possible to disassemble and replace seals of hydraulic cylinder disconnecting it from the actuator body in order to bring in a safe area.

8.3 Repairs

When needed, repair must only be carried out with Manufacturer's original spare parts.

Original spare parts must be required to the Manufacturer with reference to the item numbers shown in the next Section 10.

To ensure that right spare is provided, **serial number** printed on the RTQH series label must be specified when spares are ordered.

8.4 Reassembling

8.4.1 Hydraulic cylinder re-assembly.

Carefully clean the inside of the tube and check that the entire surface, particularly that of the bevels, is not damaged. Lubricate with a protective oil or grease film the tube internal surface and the bevels at the ends. Lubricate every seal grooves taking care there are not damages on seal surfaces.

Slide the spacer/cylinder tube onto the piston taking care not to damage the o-ring: the tube bevel has to smoothly compress the piston seal ring; take care also not to damage the head flange O-ring.

Assemble the end flange by centering it on the inside diameter of the tube, taking care not to damage the O-ring.

Assemble the nuts (please refer to cylinder sectional dwg.) onto the tie rods. Tighten the nuts to the recommended torque as per Table 1 in sec. 5.6.2, alternating between opposite corners.

8.4.2 Actuator re-assembly

Assemble the hydraulic cylinder to the housing tightening, with recommended torque table, the screw between cylinder and housing. Replace o-ring at the bottom of the housing making attention there are not dirty or damage on the seal surface, put the bushing on its seat. Re-assemble scotch yoke and guiding block, make a generous coating of grease on the contact surfaces of yoke and the bushings, assemble the guide bar and close the assemble the plug to close the guide bar. Tighten the screw between cylinder piston rod and guiding block, with recommended torque, using a wrench.. Assemble the o-ring, the cover gasket and the cover with all screw.

Recommended tighten torque as per Table 1 in Section 5.6.2.

Important 	<p>After maintenance operations carry out a few actuator operations to check that its STROKING is regular and that there is no leak through the seals and fittings.</p>
---	--

8.5 Mechanism Lubrication

RTQH actuators do not need lubrication during their life.

However, if during special maintenance operations it is necessary to replace the grease, the following products are recommended.

8.5.1 Scotch yoke mechanism (see Paragraph 10.1)

Molykote G-4700 grease produced by Dow Corning

8.5.2 Hydraulic cylinder (see Paragraph 10.2)

Rheosil 500 F oil produced by Nye Lubricant, Inc.

Important 	<p>The above products cover the full range of temperatures from -60°C up to +100°C.</p> <p>Equivalent products can be used provided that they have the same characteristics and the same range of compatibility with elastomeric and plastic components.</p>
---	--

8.6 Hydraulic Fluid

Recommended hydraulic fluids to operate the RTQH actuators are listed here below. Equivalent fluids can be used provided they have the same characteristics of the below recommended fluids.

AGIP ARNICA 22	AEROSHELL Fluid 41
To be used in standard temperature conditions (-30°C/+100°C)	To be used in low temperature conditions (-60°C/+100°C)
Manufacturer: Agip	Manufacturer: Shell
Viscosity at 40°C: 22 cSt	Viscosity at 40°C: 14,1 cSt
Viscosity at 100°C: 4,94 cSt	Viscosity at 100°C: 5,30 cSt
Viscosity Index: 157	Viscosity Index: > 200
Flash point COC: 192 °C	Flash point COC: 105 °C
Pour Point: < -39 °C	Pour Point: < -60 °C
Mass density at 15°C: 0,857 kg/l	Mass density at 15°C: 0,87 kg/l

9 TROUBLESHOOTING

Event	Possible cause	Remedy
Actuator doesn't work properly	Lack of hydraulic supply	Check supply line
	Defective main valve	Consult valve manufacturer documentation
	Failure of the control group	Call STI s.r.l. - Customer Care Dept.
Actuator too slow	Low supply pressure	Adjust supply pressure
	Incorrect speed control settings	Adjust speed controls to increase flow
	Exhaust port blocked	Remove and clean the exhaust port silencers and replace
	Wear of the main valve	Consult valve manufacturer documentation
Actuator too fast	High supply pressure	Reset
	Incorrect speed control settings	Adjust speed controls to decrease flow
Leakages on hydraulic circuits	Deterioration and/or damage to gaskets and or loosed fittings	Tightness loosed fittings Call STI s.r.l. - Customer Care Dept..
	Damage to fittings	Call STI s.r.l. - Customer Care Dept.
Leakages on hydraulic cylinder	Damage to seals	Replace cylinder seals
Incorrect position of the valve	Wrong adjustment of mechanical stops	Re-adjust setting
	Wrong electric limit switches indication.	Re-adjust setting

10 PARTS LIST GENERAL ASSEMBLY

This section includes the drawings and parts lists of each component and subassembly of RTQH series.

Important 	<p>When ordering spare parts, please indicate the serial number embossed on the actuator nameplate.</p> <p>Recommended spare parts for special or scheduled preventive maintenance are identified by index # on the next tables.</p> <p>When ordering any other part, please refer to the part item listed on the next tables</p>
---	--

10.1 Scotch yoke mechanism

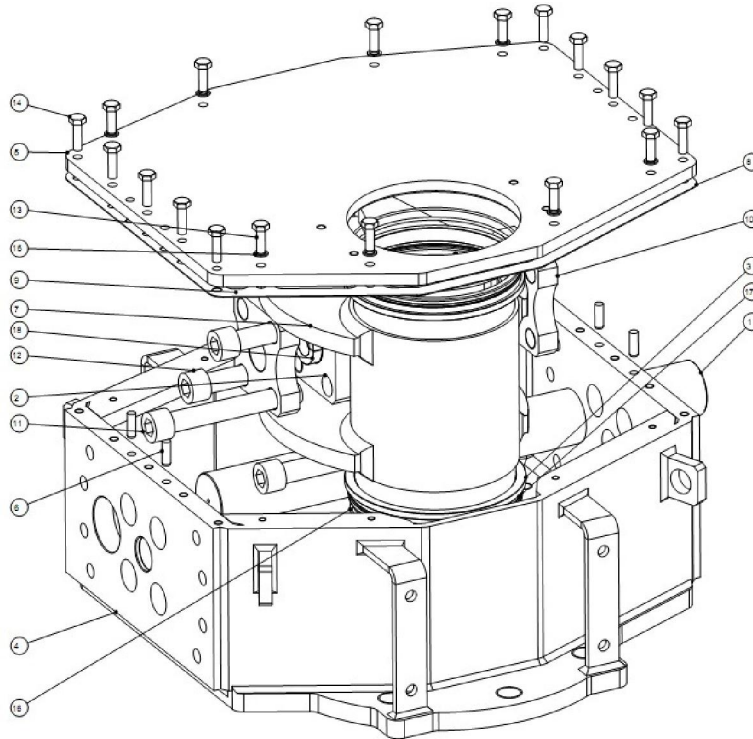

Scotch yoke mechanism part list

Item	Description	Qty	Material	Spare Parts
1	Guide Bar	1	Alloy steel	
2	Guide block	1	Carbon steel	
3	Scotch yoke bushing	2	Bronze	
4	Housing	1	Carbon steel	
5	Cover	1	Carbon steel	
6	Cylinder pin	4	Alloy steel	
7	Scotch yoke	1	Carbon steel	
8	Cover gasket	1	Fiber	#
9	Plate	1	Carbon steel	
10	Plate	1	Carbon steel	
11	Screw	2	Carbon steel	
12	Screw	2	Carbon steel	
13	Screw	(**)	Carbon steel	
14	Screw	10	Carbon steel	
15	Seal washer	(**)	Carbon steel+NBR	
16	O-ring	2	NBR (*)	#
17	O-ring	2	NBR (*)	#
18	Half ring	2	Alloy steel	

(*) NBR standard material for temperature range from -30°C up to +100°C.

(**) Quantity depends on the model.

10.2 Double acting hydraulic cylinder

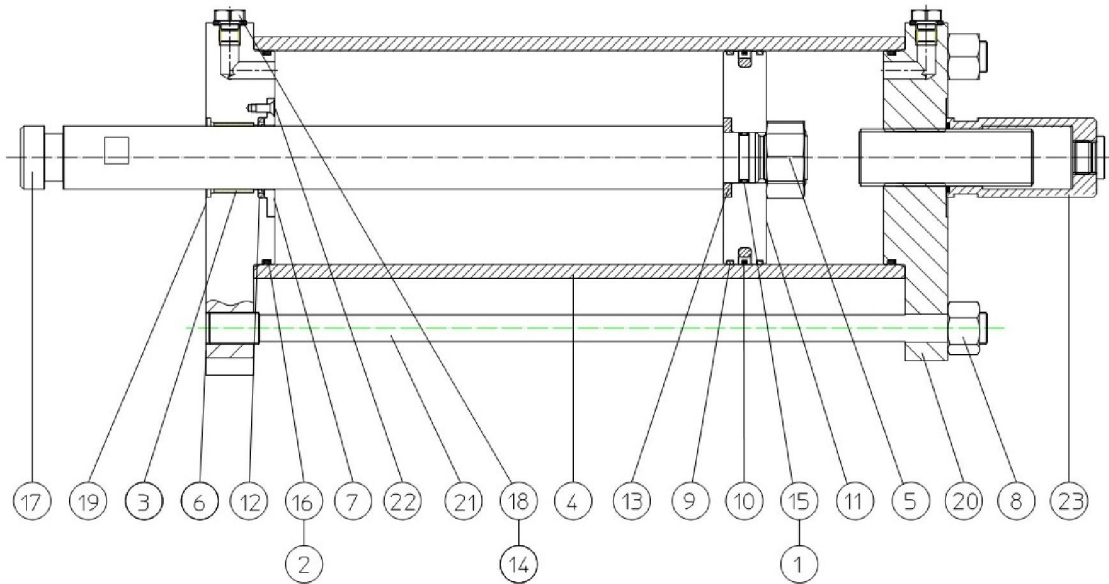

Double acting hydraulic cylinder part list

Item	Description	Qty	Material	Spare Parts
1	Back-up ring	1	NBR	#
2	Back-up ring	1	NBR	#
3	Bushing	1	Steel/Bronze/PTFE	
4	Cylinder tube	1	Carbon steel	
5	Stem nut	1	Carbon steel	
6	Plug	2	Carbon steel	
7	Retaining flange	1	Carbon steel	
8	Tie rod nut	(**)	Carbon steel	
9	Sliding guide	2	PTFE	#
10	Piston seal	1	PTFE/NBR (*)	#
11	Piston	1	Carbon steel	
12	Rod seal	1 (2)	PTFE/NBR (*)	#
13	Washer	1	Carbon steel	
14	Seal washer	2	Carbon steel/NBR	
15	O-ring	1	NBR (*)	#
16	O-ring	1	NBR (*)	#
17	Stem	1	Alloy steel	
18	Drain plug	2	Carbon steel	
19	Head flange	1	Carbon steel	
20	End flange	1	Carbon steel	
21	Tie rod	(**)	Carbon steel	
22	Screw	4	Carbon steel	
23	Stopper assembly	1	Carbon steel/Stainless steel	

(*) NBR standard material for temperature range from -30°C up to +100°C.

(**) Quantity depends on the model.

10.3 Stop protection assembly for cylinder

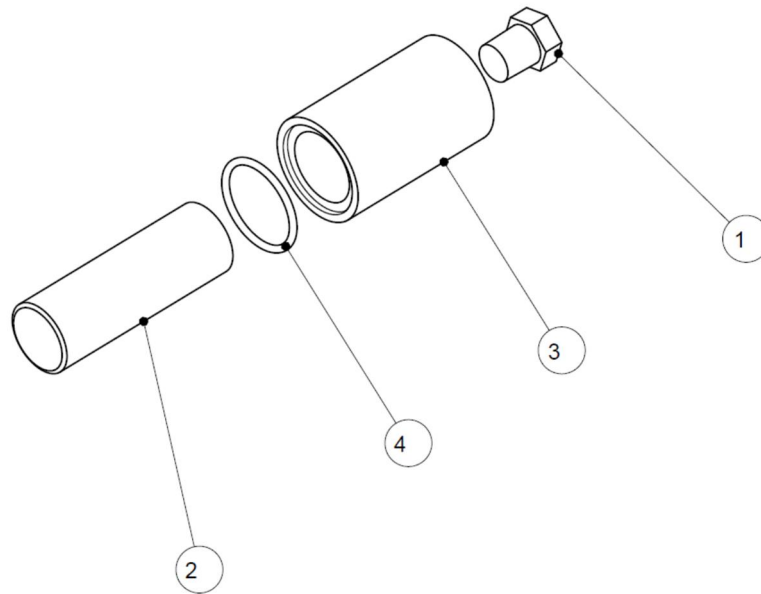

Stop protection assembly part list

Item	Description	Qty	Material	Spare Parts
1	Plug	1	Carbon steel	
2	Travel stop screw	1	Carbon steel	
3	Travel stop protection	1	Carbon steel	
4	O-ring	1	NBR (*)	#

(*) NBR standard material for temperature range from -30°C up to +100°C.

10.4 Stopper assembly for housing side wall

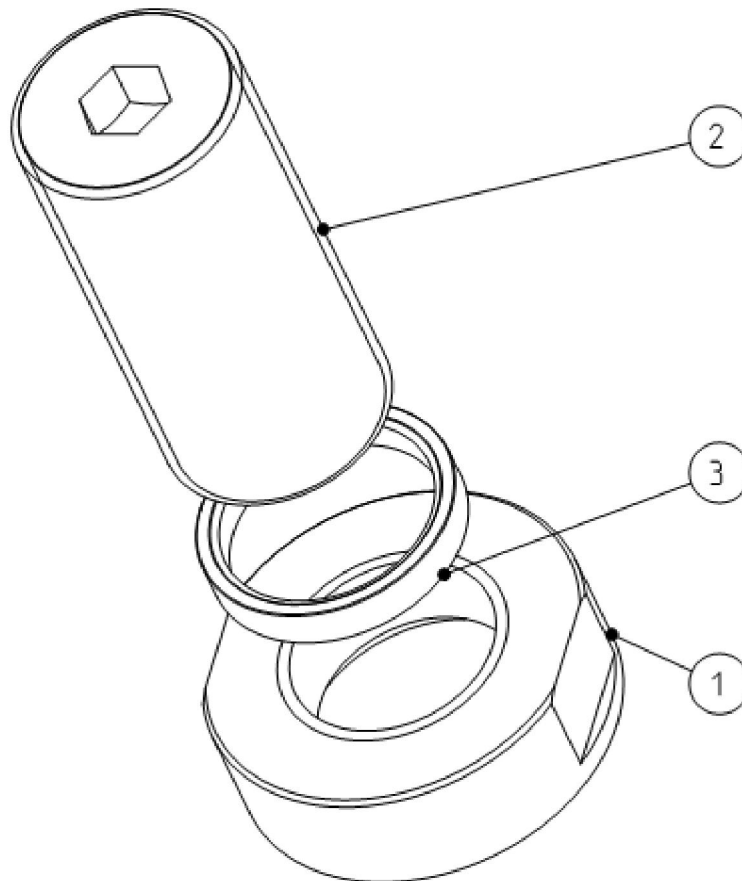

Stopper assembly part list

Item	Description	Qty	Material	Spare Parts
1	Nut	1	Stainless steel	
2	Stop screw	1	Stainless steel	
3	Seal washer	1	PTFE	#

11 SPARE PARTS

Spare part kit for double acting actuator RTQH series

General references for the recommended spare parts are shown in the tables of Section 10.

Individual kit, including all the recommended spares, can be ordered directly to STI srl provided that serial number of the actuator or specific purchasing order for the original actuator is indicated in the request.

12 DECOMMISSIONING

Disposal and recycling

Warning 	<p>Before disassembling actuator it is necessary to intercept the hydraulic connection to discharge hydraulic cylinder and control unit o the atmosphere. If present discharge also the pressure from back-up tank.</p> <p>Refer to section 5.1 and section 5.4 to lifting and storage procedure.</p> <p>If the actuator can be operated, put the actuator in fail safe position and unscrew totally the stopper screw.</p> <p>The demolition of actuator parts should be made from specialized personnel.</p>
---	--

Before starting a large area should be created around the actuator so to allow any kind of movement without problems of further risks created by work site.

Subject	Hazardous	Recyclable	Disposal
Metals	No	Yes	Use licensed recyclers
Plastics	No	Yes	Use specialist recyclers
Rubber (seals and o-rings)	Yes	No	May require special treatment before disposal, use specialist waste disposal companies
Oil and grease	Yes	Yes	May require special treatment before disposal, use specialist waste disposal companies
Electric and Electronic equipment	Yes	Yes	Use specialist recyclers

Warning 	<p>Do not re-use parts or components which appear to be in good condition after they have been checked or replaced by qualified personnel and declared unsuitable for use.</p>
---	--

Important 	<p>In all cases check local authority regulation before disposal.</p>
---	---

13 Declaration of Incorporation

 IMI STI	<p align="center">DICHIARAZIONE di INCORPORAZIONE (ai sensi dell'allegato II Sezione B della Direttiva Macchine 2006/42/CE)</p> <p align="center">DECLARATION of INCORPORATION (in accordance with EC Machinery Directive 2006/42/EC Annex II Section B)</p>
<p>La Sottoscritta STI S.r.l. con sede in Via Dei Caravaggi, 15 – 24040 Levate (BG) – ITALIA dichiara, in qualità di costruttore sotto la propria responsabilità, che la quasi-macchina qui identificata:</p> <p><i>We, STI S.r.l. based in Via Dei Caravaggi, 15 – 24040 Levate (BG) – ITALY, hereby declares, as the manufacturer under its sole responsibility, that the partly completed machinery here below identified:</i></p> <p>Denominazione Generica: Attuatore Idraulico Quarto di Giro Generic Denomination: Quarter Turn Hydraulic Actuator Tipi/Types: RTCH; RTQH (Versione doppio effetto / Double acting version) RTCHS; RTQHS (Versione singolo effetto / Single acting version)</p> <ul style="list-style-type: none"> ▪ rispetta i seguenti RESS della Direttiva 2006/42/CE <i>complies with the following EHSRs of Directive 2006/42/EC:</i> 1.1.1 - 1.1.2 - 1.1.3 - 1.1.5 - 1.2.1 - 1.2.2 - 1.3.1 - 1.3.2 - 1.3.4 - 1.3.7 - 1.3.8 - 1.4.1 - 1.5.1 - 1.5.2 - 1.5.3 - 1.5.4 - 1.5.5 - 1.5.6 - 1.5.7 - 1.5.13 - 1.6.1 - 1.7.1 - 1.7.2 - 1.7.3 - 1.7.4 ▪ è destinata ad essere incorporata/assemblata in un'altra macchina, quasi-macchine o apparecchi. <i>is intended to be incorporated into a completed machinery or assembled with other partly completed machinery or equipment.</i> ▪ non può essere messa in servizio prima che la macchina finale in cui sarà incorporata o con cui verrà assemblata sia stata dichiarata conforme alle disposizioni della direttiva 2006/42/CE. <i>must not be put into service until the final machinery into which it is to be incorporated has been declared in conformity with the provisions of Machinery Directive 2006/42/EC.</i> ▪ è conforme alle seguenti Norme Armonizzate e altre Direttive, quando applicabili al materiale installato <i>complies with the following Standards and Directives, when applicable to the material installed:</i> <ul style="list-style-type: none"> - Norma EN ISO 12100 (Ed.2010) / Standard EN ISO 12100 (Ed.2010) - Norma EN ISO 4413 (Ed.2010) / Standard EN ISO 4413 (Ed.2010) - Direttiva bassa tensione (DBT) 2014/35/UE / Low Voltage Directive (LVD) 2014/35/EU - Direttiva compatibilità elettromagnetica (EMC) 2014/30/UE <i>Electromagnetic Compatibility Directive (EMC) 2014/30/EU</i> <p>La documentazione tecnica pertinente è stata compilata in conformità dell'allegato VII Sezione B: persona autorizzata alla costituzione: STI srl c/o STI srl Via Dei Caravaggi 15 – 24040 Levate (BG) Italia <i>The relevant technical documentation is compiled in accordance with the provisions of ANNEX VII Section B;</i> person authorised to compile: STI srl at STI srl Via Dei Caravaggi 15 – 24040 Levate (BG) Italia.</p> <p>Informazioni pertinenti riguardanti la quasi-macchina saranno trasmesse, in risposta ad una motivata richiesta, alle Autorità Nazionali. <i>The relevant information concerning the partly completed machinery will be transmitted, in response to a motivated request, to the National Authorities.</i></p> <p>Il modello, il numero di matricola, l'anno di costruzione, i dati del costruttore sono riportati sulla targa fissata alla quasi-macchina. <i>The model, serial number, year of manufacture, the manufacturer's data are shown on the nameplate attached to the partly completed machinery.</i></p> <p>Levate, 10 Gennaio 2018 L'Amministratore Delegato Roberto Bertossi</p>	

IMI STI - Headquarters

Via Dei Caravaggi 15
24040 Levate (BG)
Italy

Tel. +39 035 2928.2
Fax +39 035 2928.247

IMI STI – Quarter Turn Division

Via San Francesco 18
29017 Fiorenzuola d'Arda (PC)
Italy

Tel. +39 035 2928.2
Fax +39 0523 1715.295

IMI Critical Engineering

Lakeside, Solihull Parkway
Birmingham Business Park
Birmingham B37 7XZ
United Kingdom

Tel. +44 (0)121 717 3700
Fax +44 (0)121 717 3701

www.stiactuation.com
www.imi-critical.com
imisti.sales@imi-critical.com